

DOCUMENT 3.1

Statement of Reasons

National Grid (North Wales Connection Project)

*Regulation 5(2)(h) of the Infrastructure Planning
(Applications: Prescribed Forms and Procedure) Regulations 2009*

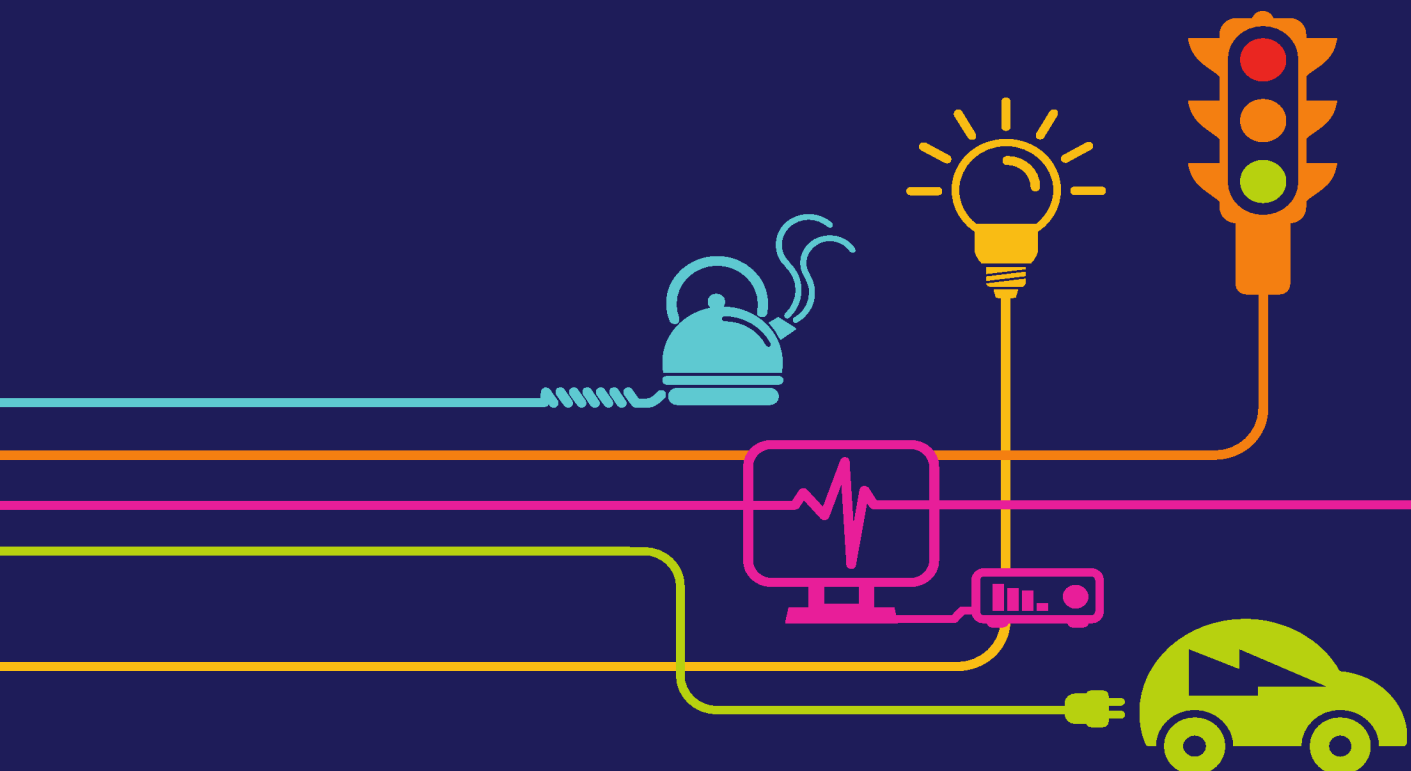

North Wales Connection Project

Volume 3

Document 3.1

Statement of Reasons

Pursuant to Regulation 5(2)(h) of the Infrastructure Planning (Applications: Prescribed Forms and Procedure) Regulations 2009
Application Ref :

National Grid
National Grid House
Warwick Technology Park
Gallows Hill
Warwick
CV34 6DA

September 2018

Page intentionally blank

Document Control			
Document Properties			
Organisation	National Grid		
Author	Steve Harkin/Ian Williams		
Approved by	Jacqueline Stoddart		
Title	Statement of Reasons		
Document Reference	3.1		
Version History			
Date	Version	Status	Description/Changes
03/09/2018	A	Final	1 st Issue

Page intentionally blank

Contents

1	Introduction	1
2	Purpose of Document	3
2.1	Requirement for this Statement of Reasons	3
3	The Need for the Proposed Development	5
3.1	The legislative and national policy statement context	5
3.2	Need case	5
3.3	Project Development	6
4	Scope of compulsory acquisition	8
4.1	Description of land and rights sought	8
4.2	Compulsory acquisition	10
4.3	Temporary Use Powers	12
4.4	Temporary use of the land by SP Manweb for carrying out the SP Manweb Works	13
4.5	Temporary use of land for maintaining the Authorised Development	13
4.6	Temporary use of subsoil under or airspace over streets	13
4.7	Other powers of note	14
5	Description of Land subject to the Compulsory Purchase and Other Powers	17
5.1	Introduction	17
5.2	the Order Land	18
5.3	Design and Consultation	20
5.4	Public rights of Way	22
6	Purpose for which the Powers Are Sought	23
6.1	General	23
6.2	Classes	23
6.3	Tables setting out purposes for which land acquired	24
7	Justification for Powers of Compulsory Acquisition	123
7.1	Section 122 of the Act	123
7.2	Section 122(2)	124
7.3	Section 122(3)	125
7.4	Alternatives to compulsory acquisition	125
7.5	Alternatives to the Proposed Development	128
7.6	The proposed interest in the land is legitimate, necessary and proportionate	128
7.7	Use of the land to be acquired	129

7.8	Availability of funds for compensation	129
8	National Grid's Approach to Acquiring Land and Rights in Land by Agreement	131
8.1	Strategy	131
8.2	Seek to acquire	132
8.3	Progress on acquisition	133
9	Related Applications, Orders, Consents	135
10	Special Category Land	136
11	Crown Land	141
12	Justification for Interference with Human Rights	146
12.1	The Human Rights Act : Relevant Convention Rights	146
12.2	Compliance with the Convention and the Human Rights Act	147
13	Conclusions	149
13.1	Need for the north wales connection project (chapter 3 within this document)	149
13.2	Scope of compulsory acquisition (chapter 4 within this document)	149
13.3	Description of the land subject to compulsory powers and other powers (chapter 5 within this document)	149
13.4	Purpose for which the powers are sought (chapter 6 within this document)	149
13.5	Justification of the power of compulsory acquisition (chapter 7 within this document)	149
13.6	National grid's approach to acquiring the required land and rights in land by agreement (chapter 8 within this document)	150
13.7	Related applications, orders, consents (chapter 9 within this document)	150
13.8	Special category land (chapter 10 within this document)	150
13.9	Crown land (chapter 11 within this document)	150
13.10	Justification for interference with human rights (chapter 12 within this document)	150

APPENDIX A – ILLUSTRATIVE TUNNEL CROSS SECTION

APPENDIX B – LOCATION PLAN

1 Introduction

1.1 NATIONAL GRID AND THE PROPOSED DEVELOPMENT

- 1.1.1 National Grid Electricity Transmission (plc) (National Grid) operates the electricity transmission system in Great Britain and owns the system in England and Wales. The system operates at 400,000 volt (400 kV) and 275,000 volt (275 kV), connecting electricity generators to substations where the higher voltages are transformed to lower voltages, enabling the power to be distributed to homes and businesses by the Distribution Network Operators (DNO).
- 1.1.2 National Grid is the only company licensed to transmit electricity in England and Wales. National Grid's Transmission Licence was granted under the Electricity Act 1989, Section 6 (1) (b).
- 1.1.3 This Statement of Reasons accompanies an application by National Grid to seek powers to construct, operate and maintain a new 400 kV connection. The Proposed Development being brought forward by National Grid is to develop a new 400 kV connection between the existing Wylfa Substation on Anglesey and Pentir Substation in Gwynedd. This would facilitate the export of power from the proposed Wylfa Newydd Power Station.
- 1.1.4 The Proposed Development is known as the North Wales Connection Project. A full description is provided in Chapter 3 of the Environmental Statement (**Document 5.3**). The Proposed Development consists of the following principal components:
- modifications to the existing substation at Wylfa;
 - sections of new 400 kV OHL between Wylfa substation and Braint Tunnel Head House (THH) and Cable Sealing End Compound (CSEC) on Anglesey including modifications to parts of the existing 400 kV OHL between Wylfa and Pentir;
 - Braint THH/CSEC on Anglesey;
 - a tunnel between Braint and Tŷ Fodol THHs;

- Tŷ Fodol THH/CSEC in Gwynedd;
- new section of OHL connection between Tŷ Fodol THH/CSEC and Pentir Substation;
- extension to the existing substation at Pentir; and
- temporary construction compounds, access tracks, construction working areas, localised widening of the public highway and third party works that are required to construct the infrastructure listed above.

2 Purpose of Document

2.1 REQUIREMENT FOR THIS STATEMENT OF REASONS

- 2.1.1 This statement has been prepared in compliance with the requirements of Regulation 5(2)(h) of the Infrastructure Planning (Applications: Prescribed Forms and Procedure) Regulations 2009 (the APR 2009) and the Planning Act 2008 (the PA 2008): Guidance related to procedures for compulsory acquisition produced by the Department for Communities and Local Government as updated September 2013 (the Guidance).
- 2.1.2 This Statement is required because the draft Development Consent Order (draft DCO) includes powers for the compulsory acquisition of land and/or rights in land as described in Chapter 5 within this document.
- 2.1.3 Paragraphs 31 and 32 of the Guidance acknowledges that the APR 2009 requires a statement of reasons and Paragraph 32 advises that:

'The statement of reasons should seek to justify the compulsory acquisition sought and explain in particular why in the applicant's opinion there is a compelling case in the public interest for it. This includes reasons for the creation of new rights'.

- 2.1.4 This Statement sets out the reasons for seeking powers for the compulsory acquisition of land and/or rights in the land. It also explains the extent of and reasons for the temporary use of land. These powers are being sought to ensure that National Grid has the requisite powers to construct, operate and maintain the Proposed Development. References in this Statement to "Compulsory Acquisition" include both permanent land acquisition, and the acquisition of rights in land.
- 2.1.5 This Statement will show that there is a compelling case in the public interest for the relevant land to be subject to powers of compulsory acquisition.
- 2.1.6 It explains why the use of powers of compulsory acquisition in these circumstances is legitimate and proportionate, and why any interference

with the human rights of those with interests in the land proposed to be acquired is justified.

2.1.7 This Statement forms part of a suite of documents accompanying the application submitted in accordance with section 55 of the PA 2008 and Regulation 5 of the APR 2009 and should be read alongside these documents. In particular National Grid has submitted the following documents in relation to compulsory acquisition powers sought as part of the Proposed Development:

- The draft Development Consent Order (**Document 2.1**)
- The Environmental Statement (**Volume 5**)
- this Statement of Reasons;
- plans showing the land over which various interests or rights over land would be acquired. The Land Plans – (**Document 4.2**);
- the Works Plans showing the proposed limits of National Grid's draft DCO, the route of the development and the distance either side of the proposed route where work may be carried out (**Document 4.4**);
- a Book of Reference containing details of interests or rights in land which may be affected by the proposed acquisition of those interests or rights (and which may be affected by the powers of temporary occupation). The Book of Reference – (**Document 3.3**);
- a Funding Statement to explain how the proposals contained in the draft DCO will be funded, including the funding to support the powers of compulsory acquisition which are sought. The Funding Statement – (**Document 3.2**);
- a Project Need Case setting out a detailed explanation of the need for the development. The Needs Case – (**Document 7.1**); and
- a document outlining the main alternatives considered. The Environmental Statement (ES) - (**Document 5.2**).

2.1.8 The Order limits of the draft DCO as shown on the Land Affected Plans (**Document 4.1**) establish the extent of the land affected by the Proposed Development. National Grid is not seeking to compulsorily acquire the full extent of the land that falls within the Order limits. In respect of the overhead line sections of the Proposed Development, National Grid will only require permanent rights to operate access and maintain the development over a corridor within the limits of deviation.

3 The Need for the Proposed Development

3.1 THE LEGISLATIVE AND NATIONAL POLICY STATEMENT CONTEXT

- 3.1.1 Six National Policy Statements (NPS) for energy infrastructure were designated by the Secretary of State (SoS) for Energy and Climate Change in July 2011. The Overarching NPS for energy (EN-1) sets out that ‘it is critical that the UK continues to have secure and reliable supplies of electricity as part of the transition to a low carbon economy.’ EN-1 also highlights an urgent need for new electricity transmission and distribution infrastructure to be provided. Paragraph 3.7.2 of EN-1 states;

‘As noted in Parts 2 and 3 of this NPS, it is likely that demand for electricity will increase significantly over the coming decades. Factors contributing to such growth include the development of new housing and business premises the number of households in England is projected to grow to 27.8 million by 2031 and the increased use of electricity in domestic and industrial heat and transport. Lack of sufficient robust electricity networks can cause, or contribute to, large scale interruptions. Existing transmission and distribution networks will have to evolve and adapt in various ways to handle increases in demand, but construction of new lines of 132kV and above will also be needed to meet the significant national need for expansion and reinforcement of the UK’s transmission and distribution networks.’

- 3.1.2 In addition EN-5 the NPS for Electricity Networks Infrastructure states:

“new lines will have to be built, and the location of renewable energy sources and designated sites for new nuclear power stations makes it inevitable that a significant proportion of those new lines will have to cross areas where there is little or no transmission infrastructure at present, or which it may be claimed should be protected from such intrusions”.

3.2 NEED CASE

- 3.2.1 A detailed explanation of the need for the Proposed Development is contained in the Project Need Case (**Document 7.1**).
- 3.2.2 The National Electricity Transmission Security and Quality of Supply Standards (NETS SQSS) establish a coordinated set of criteria and

methodologies that National Grid uses in the planning and operation of the National Electricity Transmission system. Additional criteria, for example covering more detailed and other aspects of quality of supply are contained in the Grid Code and the System Operator Transmission Owner (SO-TO) Code.

3.2.3 Under the terms of its transmission licence, National Grid is obliged to make an offer of connection in response to each valid application made. National Grid received an application from Horizon Nuclear Power for the connection of a proposed nuclear power station at Wylfa on the north coast of Anglesey to the high voltage electricity transmission system.

3.2.4 National Grid has contractually agreed to connect Wylfa Newydd Power Station to the transmission system in North Wales in 2026-2027. The existing overhead line between Wylfa and the mainland is insufficient to allow Wylfa Newydd to connect, therefore National Grid needs to build a new, second connection.

3.3 PROJECT DEVELOPMENT

3.3.1 As the North Wales Connection Project is a Nationally Significant Infrastructure Project (or NSIP), National Grid needs to submit an application for development consent to the Secretary of State for Business, Energy and Industrial Strategy via the Planning Inspectorate. The application will be for a draft Development Consent Order under the Planning Act 2008.

3.3.2 The pre-application process is a significant component of the draft DCO process. It involves the development of a scheme that has been tested and subjected to review, consultation and environmental assessment so that, when a draft DCO application is submitted, the scheme represents a balance of environmental, socio-economic, cost and technical factors, taking account of consultation feedback through statutory and non-statutory routes. It also includes surveys, environmental assessments and the preparation of all draft DCO application documents.

3.3.3 National Grid commenced the pre-application process for the proposed development in 2012. The figure below outlines the proposed development process; further details can be found in Chapter 2 of the Environmental Statement (**Document 5.2**).

Overview of the Proposed Development Evolution

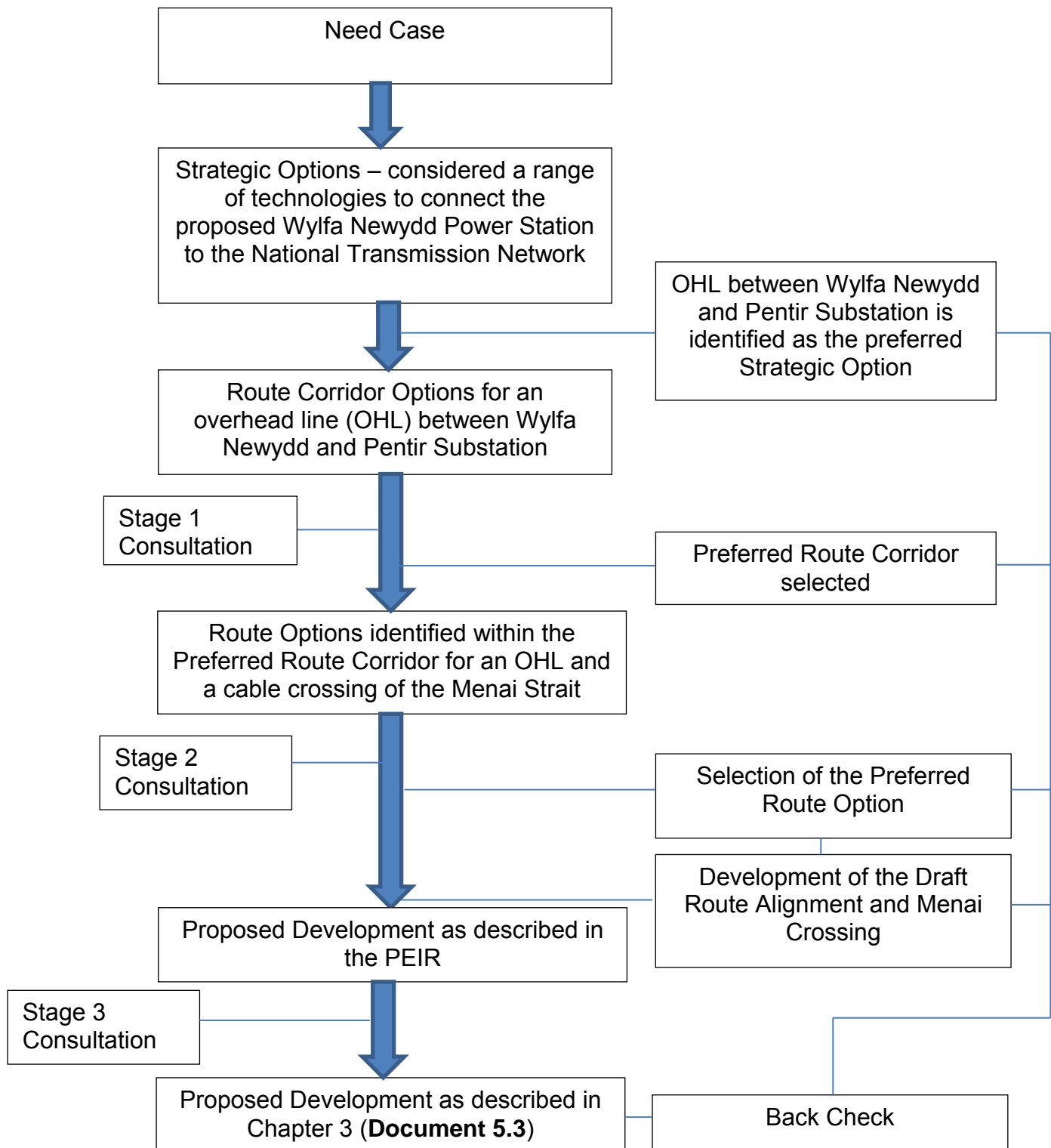

4 Scope of compulsory acquisition

4.1 DESCRIPTION OF LAND AND RIGHTS SOUGHT

- 4.1.1 National Grid seeks both permanent and temporary powers in the draft DCO to construct, operate, and maintain the Proposed Development. For these purposes, National Grid requires the compulsory acquisition of land, and rights over land, and powers for the temporary use of land for dismantling, construction, operation and maintenance.
- 4.1.2 In relation to the SP Manweb Works, the draft DCO contains provisions for SP Manweb to acquire rights over land and to possess land temporarily. In addition to the SP Manweb Works, there are also works required as part of the Authorised Development¹ to other undertakers' equipment, such as Openreach. Those works form part of the Authorised Development and National Grid is in discussion with such undertakers about those works.
- 4.1.3 The nature of the majority (by length) of the Proposed Development (i.e. an overhead electricity line) is such that very little land will need to be compulsorily acquired. The majority of the acquisition powers relate to the acquisition of rights (both for towers and oversail of overhead conductors).
- 4.1.4 Such acquisition of land as is required is at and around Pentir substation and at and around the 2 tunnel head house (THH) locations at Braint and Tŷ Fodol.
- 4.1.5 In respect of the tunnel that will be constructed including beneath the Menai Strait, a freehold stratum of subsoil will be sought. As with other parts of the Proposed Development, it is proposed that the tunnel would be constructed pursuant to the temporary occupation power in the draft DCO (article 26), and then insofar as necessary powers of compulsory

¹ "Authorised Development" is a term defined in the draft DCO.

acquisition would be exercised on completion of construction.² National Grid considers a consistent protective zone all around the tunnel to be necessary to accommodate rock bolts and grouting so that none of the construction works go outside of the LOD. The land required will be no greater than a 25 m by 25 m cross section. This is considered to be proportionate to the nature and scale of the main tunnel once constructed. An illustrative tunnel cross section is included at **Appendix A** of this document.

- 4.1.6 In respect of the associated shafts these will be within the THH compounds and will fall within the freehold land to be acquired in each case.
- 4.1.7 The land in respect of which powers of compulsory acquisition and the acquisition of rights are sought, is defined in the Book of Reference (**Document 3.3**) and shown on the Land Plans (**Document 4.2**). For completeness, the Book of Reference and the Land Plans also identify those plots in respect of which powers of temporary use are sought. The draft DCO makes provision that certain scheduled plots may only be used temporarily (those plots set out in Schedule 11 to the draft DCO) and that all other Order land may be both used temporarily and then be subject to powers of compulsory acquisition. This approach is that which has been taken on many other linear NSIPs and indeed linear Transport and Works Act Order schemes, whereby the land necessary for construction is occupied and used temporarily, and then the powers of compulsory acquisition are intended to be exercised only once the Proposed Development has been completed. This enables a proportionate approach to the land required, whilst also aligning with the flexibility required and as set out in the draft DCO and on the Works Plans (for example the Limits of Deviation).
- 4.1.8 The nature of the Proposed Development is such that it is necessary to acquire interests in and rights over land and take powers to temporarily use land. This document seeks to justify the inclusion of such rights and powers in the draft DCO.

² See also Section 12 of this document in relation to Crown Land.

4.2 COMPULSORY ACQUISITION

- 4.2.1 The draft DCO includes the following powers that relate to compulsory acquisition:

Article 22 - Compulsory acquisition of land

This Article allows National Grid (but not SP Manweb) to compulsorily acquire land as necessary to construct, operate and maintain the Authorised Development or is incidental to it or necessary to facilitate it.

Article 23 – Compulsory acquisition of rights

This Article allows National Grid, or SP Manweb with respect to SP Manweb Works, to compulsorily acquire rights or impose restrictions, over the land insofar as these are necessary to construct, operate and maintain the Authorised Development.

Article 24 – Acquisition of subsoil or airspace

This Article grants National Grid, or SP Manweb with respect to SP Manweb Works, the power to acquire land below a certain depth under the ground or above a certain height above it, rather than having to acquire all of the land.

Article 25 – Acquisition of land limited to subsoil lying more than 9 metres beneath the surface

This article restricts the power in Article 22 to compulsorily acquire land in respect of the plots that may be required for the tunnel, such that only deep subsoil may be acquired. Those plots are listed in Schedule 10 to the draft DCO. In addition, in respect of some of the plots where the tunnel may be constructed, the Proposed Development also includes works at surface level, necessitating the acquisition of rights (class 3 or class 4) and these are shown on the Land Plans, by way of both the shading for class 3 or class 4 rights, as well as cross-hatching for class 2 deep subsoil acquisition.

- 4.2.2 The draft DCO includes the following ancillary / consequential articles that relate to compulsory acquisition:

Article 33 – Time limit for exercise of authority to acquire land compulsory

This limits the ability to serve a notice to treat of a general vesting declaration to a period within 8 years from the granting of the Order.

Article 32 – Compulsory acquisition of land – incorporation of the mineral code

This effectively exempts rights in minerals from the scope of compulsory acquisition and provides for a procedure for the owner wishing to work mines or minerals.

Article 34 – Acquisition of part of certain properties

This Article allows for National Grid, or SP Manweb with respect to SP Manweb Works, to acquire only part of certain properties.

Article 35 – application of the compulsory purchase (vesting declarations) Act 1981

This Article provides for the application, with modifications (for example by virtue of the Housing and Planning Act 2016), of the Compulsory Purchase (Vesting Declarations) Act 1981 which contains vesting procedures for land subject to compulsory purchase.

Article 36 – application of Part 1 of the 1965 Compulsory Purchase Act

This Article ensures that existing compulsory acquisition legislation and the draft DCO are properly aligned.

Article 37 – extinguishment and Suspension of private rights

This Article allows for the extinguishment or suspension of private rights over land.

Article 38 – power to override easements and other rights

This Article allows for the overriding of interests and rights, including restrictions as to use of land. It addresses both use of land and other activities pursuant to the draft DCO, and draws on the provisions of Section 203 of the 2016 Act.

Article 39 – Statutory authority to override easements and other rights

This Article provides, for the avoidance of doubt, that by virtue of Section 158 of the Planning Act 2008, that the undertaker has statutory authority to interfere with certain interests and rights.

Article 40 – Extinguishment of private rights and restrictive covenants relating to apparatus belonging to National Grid or SP Manweb removed from land subject to temporary possession

All private rights over land that is temporarily occupied by the undertaker are suspended and unenforceable insofar as inconsistent with the exercise of the draft DCO power, for the duration of occupation. This article provides that where National Grid or SP Manweb's apparatus is removed from the

land, then rights in relation to that apparatus are extinguished, when National Grid or SP Manweb are no longer in lawful possession of the land. Where foundations below 1.5m are left in situ, the Article provides that there is no cause of action notwithstanding the extinguishment of the land rights.

- 4.2.3 Rule 5(2)(h) of the APR 2009 requires a statement of reasons for seeking a DCO to authorise “the compulsory acquisition of land or an interest in or right over land”. Regulation 5(2)(h) does not therefore require the statement of reasons to extend beyond the outright acquisition of land or interests in or rights over land. This, however, does not capture other compulsory powers sought in the draft DCO which similarly relate to land and will or may interfere with property rights and interests. These are addressed below.

4.3 TEMPORARY USE POWERS

- 4.3.1 Article 26 would enable National Grid for the purposes of constructing the Authorised Development, to take temporary possession of certain land. ‘Possession’ means that National Grid could occupy and control the land to the exclusion of others including its owner; however this is not the compulsory acquisition of the land or the compulsory acquisition of permanent and temporary rights in land. Such temporary use powers are expressly differentiated from compulsory acquisition, including by the relevant secondary legislation, being statutory ‘powers’, rather than the ability to compulsorily acquire a right attaching to land. This approach very much reflects the approach taken in many made DCOs, and indeed in the predecessor regime under the Transport and Works Act 1992.
- 4.3.2 The land to which Article 26 applies is the land specified in column 1 of Schedule 11 to the draft DCO (being land in respect of which only temporary use powers apply, with no ability to permanently compulsorily acquire land or rights) and any other land within the Order limits, provided that National Grid has not made a declaration to vest the land in itself or enter the land following service of a notice of entry in advance of acquisition.
- 4.3.3 National Grid can carry out those activities specified in Article 26. These include the removal of electric line, plant, buildings, structure, pylons, apparatus and vegetation; the construction of temporary works and buildings and the construction of any works specified in relation to that land in Schedule 11.
- 4.3.4 The period of temporary possession would be subject to the time limits set out in Article 33(2) and Article 26. Before giving up temporary possession

of land, National Grid would be obliged to remove all temporary works and restore the land, subject to the stated exceptions.

4.4 TEMPORARY USE OF THE LAND BY SP MANWEB FOR CARRYING OUT THE SP MANWEB WORKS

4.4.1 Article 27 would allow SP Manweb to take temporary possession of the Order Land including as specified in column (1) of Schedule 11 of the draft DCO in relation to the SP Manweb Works.

4.4.2 Article 27 contains provisions applicable to SP Manweb in respect of that land in the same form as those applicable to National Grid under Article 26.

4.5 TEMPORARY USE OF LAND FOR MAINTAINING THE AUTHORISED DEVELOPMENT

4.5.1 Article 28 would enable National Grid and SP Manweb (in relation to the SP Manweb Works) to take temporary possession of certain land at any time during the maintenance period (i.e. in relation to any part of the Proposed Development, 5 years from the date on which that part is first opened for operational public use (save for replacement or landscape planting for which there is an exception)).

4.5.2 The land to which Article 28 applies is any land within the Order limits of the draft DCO.

4.5.3 Article 28(1)(b) would allow the construction of temporary works and buildings on the land, so far as is reasonably necessary for maintenance purposes.

4.5.4 The powers are subject to a time limit with National Grid and SP Manweb only able to remain on the land for so long as reasonably necessary to carry out the maintenance works. Before giving up possession there is a requirement to remove all temporary works and restore the land to the owner's reasonable satisfaction.

4.5.5 The exercise of the powers would interfere with the property rights of owners and occupiers. An owner or occupier suffering loss or damage would be entitled to claim compensation.

4.6 TEMPORARY USE OF SUBSOIL UNDER OR AIRSPACE OVER STREETS

4.6.1 Article 29 allows National Grid or SP Manweb to use subsoil under or airspace over streets, such that where the Proposed Development passes

over or under a street, the relevant land may be possessed temporarily for the construction of the works.

4.6.2 Any owner or occupier is entitled to compensation as set out in Article 29.

4.7 OTHER POWERS OF NOTE

Additional powers which the draft DCO would confer on National Grid (or SP Manweb in respect of the SP Manweb Works) are:

Article 11 – street works

This Article would allow National Grid (and SP Manweb in respect of SP Manweb Works) to carry out certain specified kinds of works in certain streets. The exercise of these powers could potentially interfere with private rights.

Article 13 – Power to alter layout etc, of streets

This Article would allow National Grid (and SP Manweb) to permanently or temporarily alter the layout or carry out certain works in the streets. If there are any private rights over the streets, the exercise of powers in Article 13 could potentially interfere with these. In that event the rights in question would be suspended; extinguished or otherwise interfered with.

Article 14 – Temporary stopping up of streets and public rights of way.

This article would enable National Grid (and SP Manweb) to temporarily stop up, alter or divert streets and public rights of way and to use any such street as a temporary working site. The power would only be exercisable for the purpose of constructing the proposed development. Any stopping up would be for a reasonable time only.

The power to prevent pedestrian access would be subject to the obligation to provide reasonable access for pedestrians going to or from premises abutting a street affected by the temporary stopping up, alteration or diversion if there would otherwise be no access.

The exercise of Article 14 could potentially interfere with private rights (i.e. rights vested in a person rather than the public at large) such as rights to drive vehicles along a temporarily stopped up street. In that event the right in question would be suspended. A person suffering loss due to such suspension would be entitled to claim compensation.

Article 18 – Discharge of Water

Under Article 18, National Grid, (or SP Manweb in relation to the SP Manweb Works), may use any watercourse or any public sewer for the

drainage of water in connection with the carrying out or maintenance of the Proposed Development. This may include laying down, taking up or altering pipes and making openings into and connections with the watercourse, public sewer or drain.

Consent from the owner of the relevant watercourse, public sewer or drain must be obtained before any water is discharged into it.

National Grid (or SP Manweb) must ensure that as far as reasonably practicable, steps are taken to secure that water discharged into the watercourse, public sewer or drain is as free as possible from gravel, soil or other solid substance oil, or matter in suspension.

Article 19 – Protective works

Article 19 enables National Grid (or SP Manweb in respect of the SP Manweb Works) to carry out such protective or remedial works to land, buildings, structures, apparatus or equipment, lying within the Order limits or as may be affected by the Proposed Development, as it considers necessary or expedient. Protective works may be carried out prior to commencing construction of the Proposed Development, during construction of the development or up to five years after the development has been completed.

National Grid (or SP Manweb) may enter and survey any building for the purpose of determining how the functions under this Article are to be exercised.

Relevant notices must be served on the owners and occupiers of the building or land as set out in Article 19. An owner or occupier suffering loss would be entitled to claim compensation.

Article 20 – Authority to survey and investigate the land

This Article would enable National Grid, or SP Manweb in respect of the SP Manweb Works, for the purposes of the DCO, to enter onto any land shown within the Order limits, or which may be affected by the Authorised Development, to survey and investigate the land. A person suffering loss due to such interference would be entitled to claim compensation.

Article 41 – Statutory undertakers

Article 41 allows National Grid (or SP Manweb in relation to SP Manweb Works) to acquire land, or rights over land, belonging to statutory undertakers in so far as it falls within the Order limits. National Grid can extinguish the rights of, or remove apparatus belonging to statutory undertakers.

Article 42 – Special category land

In respect of special category land see Chapter 10 within this Statement.

Article 42 allows National Grid to carry out the Proposed Development on special category land notwithstanding its status as such.

Article 47 – Traffic Regulation

Article 47 allows National Grid (or SP Manweb in respect of the SP Manweb Works) to prohibit vehicular access, prohibit waiting of vehicles and regulate vehicular speed, and prohibit use of roads by through traffic, regulate the direction of vehicular movements, and impose clearway, for the purposes of the construction of the Proposed Development. The extent to which the roads can be interfered with is set out in Schedule 13.

The powers set out in this Article may only be exercised with the consent of the traffic authority in whose area the road is situated. National Grid (or SP Manweb in respect of the SP Manweb Works) must comply with the relevant notice and advertising periods as set out in the Article.

Article 48 – Felling or lopping of trees

This Article would enable National Grid (or SP Manweb in respect of the SP Manweb Works) to fell, lop, prune, coppice, pollard or reduce in height or width, any tree, shrub, hedgerow or important hedgerow, within or overhanging land within the Order limits so as to prevent the trees or shrubs from obstructing or interfering with the construction, maintenance or operation of the Proposed Development or which may cause a danger. A person suffering loss due to such interference would be entitled to claim compensation.

Article 49 – Trees subject to Tree Preservation Orders

This Article grants similar powers to National Grid (or SP Manweb in respect of the SP Manweb Works) as those contained in Article 48 but in relation to trees subject to a Tree Preservation Order. A person suffering loss due to such interference would be entitled to claim compensation.

5 Description of Land subject to the Compulsory Purchase and Other Powers

5.1 INTRODUCTION

- 5.1.1 This chapter describes the Order Land, including its location, use and topography. The land which is to be subject of compulsory acquisition is shown on the Land Plans (**Document 4.2**) and identified in the Book of Reference (**Document 3.3**) and the works including the LoD are shown on the Works Plans (**Document 4.4**).
- 5.1.2 National Grid is seeking temporary powers over a wider area within the Order limits to provide a necessary and proportionate degree of flexibility as to the final alignment of the works. National Grid has reduced the Limits of Deviation (LoD) and parameters as much as reasonably possible but needs to ensure there is some flexibility if necessary (which is explained further in the Environmental Statement Chapter 6 (**Document 5.6**)). As described above, the approach of first using temporary possession powers to construct the Proposed Development and only then exercising powers of compulsory acquisition once the section of the Proposed Development has been constructed, maintains the flexibility in the draft Order and as shown on the Works Plans, and offers a proportionate approach to the land powers sought.
- 5.1.3 For example, the lateral LoD is generally 50 metres from the centreline meaning that the ability to move pylons laterally is limited to around 20 metres dependent upon the local geometry of the overhead line. In some areas the Limits of Deviation have been significantly reduced to further limit the extent of potentially affected land where that land is considered particularly sensitive e.g. residential curtilages. These Limits of Deviation, along with vertical LoD, provide the engineers with a degree of flexibility to enable them to build assets in a slightly different location to the original detailed design. There is always a risk during the construction phase of a project of finding new or unrecorded features such as archaeological remains or populations of protected species (e.g. great crested newts or badgers). In these cases the LoD enable minor changes to design without

requiring the undertaker to re-apply for consent. A full description of the extent of land required by National Grid in order to carry out construction of the Proposed Development and later, access and maintenance, is set out at Chapter 4 of the ES (**Document 5.4**).

5.1.4 The Proposed Development would be subject to specific requirements, regarding the approved plans, and construction works and methodology set out in the draft DCO.

5.1.5 The land to which the powers sought relate is in North Wales and crosses the administrative boundaries of the following county authorities:

- Isle of Anglesey County Council
- Gwynedd County Council

In addition a small section of the route passes beneath coastal waters below mean low water which lies beyond the jurisdiction of either Council as planning authority.

5.1.6 The geographical extent of the Order Land is illustrated below in the Location Plan **Appendix B** see also Overall Location Plan (**Document 4.0.1**).

5.2 THE ORDER LAND

5.2.1 The area within the Authorised Development's Order limits is approximately 744 hectares principally extending south eastwards from Wylfa Substation on Anglesey, passing under the Menai Strait, to the existing Pentir Substation in Gwynedd. A more detailed description of the different land and existing uses of the land for each section is detailed below with reference to the relevant chapters contained in the Environmental Statement (**volume 5**).

5.2.2 For ease of reference, the Order Land has been divided into six sections referenced A- F from Wylfa to Pentir. These are detailed below :

Section A - Wylfa to Rhosgoch

Section B - Rhosgoch to Llandyfrydog

Section C - Llandyfrydog to B5110 north of Talwrn

Section D - B5110 north of Talwrn to Ceint

Section E - Ceint to the Afon Braint

Section F - Afon Braint to Pentir

Section A – Wylfa to Rhosgoch.

The land within Section A of the Proposed Development commences at Wylfa Substation and extends easterly towards Rhosgoch, passing to the north and east of the villages of Tregele and Llanfechell. In this section of the Order Land the new line would be to the east of the existing line and is on what will be termed the 4ZA alignment. The Order Land extends across the A5025 and heads south-east to the end of the section north of the settlement of Rhosgoch.

Section B - Rhosgoch to Llandyfrydog

The land within Section B of the Proposed Development runs in a north-west to south-east direction along the route of the existing overhead line from a location south of Bodewryd, where Section A changes into Section B. It then heads south-east to pass immediately south of Rhosgoch and Rhosybol and crosses the B5111 before reaching Llandyfrydog where Section B ends and C begins.

Section C - Llandyfrydog to B5110 north of Talwrn

The land within Section C commences east of the settlement of Llandyfrydog and extends in a south-easterly direction towards the hamlet of Maenaddwyn, passing to the west of Hebron and then to the north of the village of Capel Coch. To the north-east of Capel Coch the Order Land extends south, to the east of Capel Coch adjacent to the Anglesey Fens Special Area of Conservation (SAC). After crossing the Afon Erddreiniog the Order Land turns south-east where it converges back to close parallel with the existing overhead line at Maen Eyr. The two lines then run in close parallel for the remainder of this section to a point to the south of the B5110. The two lines are not in close parallel for approximately 2.6 km through this section to avoid direct effects from the new overhead line on the Anglesey Fens SAC.

Section D - B5110 north of Talwrn to Ceint

The land within Section D commences to the south of the B5110. The two lines continue in a south-easterly direction crossing the B5109 to the west of Talwrn and the B5420 to the east of Llangefni where the section ends. The two lines are in close parallel for the entire section.

Section E - Ceint to the Afon Braint

The land within Section E commences south of the B5420 to the east of Llangefni. The two lines continue south south-east in close parallel to pylon 4ZA078 at which point the new 4AP overhead line diverts away from the

existing 4ZA overhead line. The new 4AP overhead line continues south-east crossing the A55, A5 and railway between Garnedd fawr and Tyddyn-isaf continuing to the end of this section where the overhead line crosses the Afon Braint.

Section F - Afon Braint to Pentir

The overhead line in Section F is split into a short section of overhead line, comprising of one pylon on Anglesey to the proposed 400 kV gantries at Braint Cable Sealing End Compound. A section of overhead line, comprising of four pylons in Gwynedd from the proposed 400 kV gantries at Tŷ Fodol Cable Sealing End Compound south across Coed Nant y Garth to Pentir Substation.

5.3 DESIGN AND CONSULTATION

- 5.3.1 The design for the 400 kV overhead line and lower voltage diversions is based on environmental, technical and economic studies as well as consideration of consultation responses in respect of the Proposed Development. The Environmental Statement provides full details of the baseline environment in which the Proposed Development would be constructed for the relevant technical topic.
- 5.3.2 The Consultation Report (**Document 6.1**) contains full details of the consultation process.
- 5.3.3 A process was implemented to consider all consultation feedback received and to decide whether it was appropriate to adopt any requested changes to the proposed design. These changes were identified through feedback from the public information events, ongoing discussions with prescribed, non-prescribed and other bodies and from discussions with landowners and persons with an interest in the land (PILs) potentially affected. The process was developed to ensure that each identified design change was effectively assessed by National Grid's specialist teams covering environment, design and construction and land rights.
- 5.3.4 The procedure was applied to all relevant design changes to either the location and/or design of the proposed infrastructure or access works associated with the Proposed Development. Design changes were raised in relation to matters such as the overhead line route, individual pylon locations, tunnel head house locations and access routes. The Environment Statement provides full details of the baseline environment in which the Proposed Development would be constructed for the relevant technical topic.

5.3.5 In broad terms the processes comprised the following stages:-

- **Preliminary assessment** : Each design change was initially reviewed by the technical leads (engineering, land rights, environment and socio-economics) to consider the proposed design change, including whether it was feasible, and should therefore be subject to more detailed appraisal.
- **Engineering study** : A revised engineering design, taking into account known environmental and socio-economic information, was developed for the next stage of the process.
- **Full assessment** : The technical specialists reviewed all the relevant information and considered whether the requested change might be preferable to the draft design presented for consultation. A multi-disciplinary workshop was held to consider whether the change should be made having regard to matters including the outcome of the appraisals in the context of feedback, planning policy and National Grid's statutory duties.

5.3.6 The area where the Proposed Development would take place is predominantly rural land in agricultural use, with residential development in the surrounding area.

5.3.7 Major access routes within and around the Order limits include the A55 which provides access between Gwynedd and Anglesey via the Britannia Bridge.

5.3.8 The following nationally and internationally designated nature conservation sites fall partly within the Order limits:

5.3.9 Cors Erdreinniog Special Area of Conservation (SAC), SSSI, Ramsar Site and National Nature Reserve.

5.3.10 Menai and the Sarnau SAC (the tunnel passes beneath this site)

5.3.11 There are no nationally designated Scheduled Monuments within the Order limits.

5.3.12 There are also several areas of ancient woodland within the Order limits.

5.4 PUBLIC RIGHTS OF WAY

- 5.4.1 There are several public rights of way running through the areas identified as Order Land, shown on the Access and Rights of Way Plans (listed at Schedule 2 Part 1 of the draft DCO and at **(Document 4.5)**), which shows the PRow that will be affected by the Proposed Development. Article 14 of the draft DCO for the Proposed Development would grant the necessary powers to stop up temporarily PRow affected by the Proposed Development. It is however National Grid's intention to keep the majority of the PRow effectively open via management.
- 5.4.2 The PRow Management Plan **(Document 7.6)** describes where the PRow will be affected by the Proposed Development and how the PRow will be managed to ensure these are safe to use and that the disruption to users of the PRow is minimised. The Access and Rights of Way Plans (listed at Schedule 2 Part 1 of the draft DCO, **(Document 4.5)**) which are produced in support of the DCO application show all of the PRows within the Order Land and proposed temporary diversion routes where necessary.

6 Purpose for which the Powers are Sought

6.1 GENERAL

- 6.1.1 The purpose of the compulsory acquisition powers is to enable National Grid (and SP Manweb in respect of the SP Manweb Works) to install, operate and maintain a new 400 kV electricity transmission connection (including the installation of a 400 kV overhead line) together with the works to the local electricity distribution network. The need for the Proposed Development is set out in the Project Need Case (**Document 7.1**). For that purpose a range of land and rights is necessary.
- 6.1.2 Broadly stated, the purpose of acquisition powers is to enable National Grid (and SP Manweb in respect of the SP Manweb Works) to construct the works, to subsequently operate the works and to be able to maintain the Proposed Development. It is for that overarching purpose that the draft DCO contains powers for the compulsory purchase of land and rights over land.
- 6.1.3 Without the powers to compulsorily acquire the land and rights, and to temporarily use land, it would not be possible to deliver the Proposed Development within the timescales required to meet the need, if at all. This would have an impact on energy security and energy markets.

6.2 CLASSES

- 6.2.1 In relation to the relevant land as referred to on the Land Plans (**Document 4.2**) and the Book of Reference (**Document 3.3**), there are 6 classes under which the land or rights may be acquired permanently or land used temporarily. These have been identified by considering the different types of powers required to construct operate and maintain the Authorised Development and then identifying which of those powers National Grid (and in turn SP Manweb in respect of the SP Manweb works) will require in relation to each parcel of land. The classes are listed in order of magnitude in the Book of Reference and each class includes all subordinate rights within the lesser classes.
- 6.2.2 National Grid's class of interests and rights is set out in the Book of Reference, with the National Grid class indicated first in each case, and

then secondly with SP Manweb’s class also set out after a ‘/’. As detailed in the Book of Reference, National Grid is anticipating delivering the Authorised Development in respect of the National Grid 400 kV connection, and SP Manweb is expected to deliver the SP Manweb Works. However to ensure delivery of the entire Authorised Development, National Grid must be able to deliver all works forming part of the Authorised Development (if needs be including the SP Manweb Works), hence National Grid must have at least the same land powers as SP Manweb, to allow for any such ‘step in’.

6.3 TABLES SETTING OUT PURPOSES FOR WHICH LAND MAY BE ACQUIRED

6.3.1 The purposes for which the land subject to the powers of compulsory acquisition of land and rights, and temporary uses required is set out in Tables 6.1, 6.2 and 6.3 below. This is described according to the numbered works set out in Schedule 1 to the draft DCO (**Document 2.1**) and the plot numbers shown on the Land Plans, (**Document 4.2**) which should be read in conjunction with, and by reference to these documents.

Table 6.1: Compulsory Acquisition of land

NATIONAL GRID COMPULSORY ACQUISITION OF LAND (classes 1 and 2)	
No. on Plan	Purpose for which land may be acquired
A1-093, A1-094, A4-034, A4-037, E3-091, E3-095, E3-104, E3-109, E3-121, E3-132, E3-138, E4-012, E4-013, E4-014, E4-022, E4-027, E4-030, E4-034, E4-038, E4-044, F1-006, F1-008, F1-010, F1-011, F1-032, F1-051, F1-052, F1-067, F1-068, F1-071, F1-073, F1-075, F1-076, F1-079, F1-081, F1-084, F1-085, F1-090, F1-092, F1-093, F1-094, F1-095, F1-097, F1-098, F1-100, F1-101, F1-102, F1-104, F1-107, F1-108, F1-111, F1-112	Construction, operation and maintenance of the authorised development
F1-113	Construction, operation and maintenance of the authorised development more than 9 metres beneath the surface
F1-114	Construction, operation and maintenance of the authorised

	development
F1-115, F1-116, F1-117, F1-118, F1-119, F1-120, F1-122, F1-123, F1-124, F1-125, F1-126, F1-128, F1-130, F1-137, F1-138, F1-139, F1-140, F1-142, F1-143, F1-144, F1-145, F1-146, F1-147, F1-148, F1-149, F1-150, F1-151, F1-152, F1-153, F1-154, F1-155, F1-156, F1-157, F1-158, F1-159, F1-160, F1-161, F1-162, F1-163, F1-164, F1-165, F1-166, F2-001, F2-002, F2-003, F2-004, F2-005, F2-006, F2-007, F2-008, F2-009, F2-010, F2-011, F2-012, F2-013, F2-014, F2-015, F2-016, F2-017, F2-018, F2-019, F2-020, F2-021, F2-022, F2-023, F2-024, F2-024a, F2-025, F2-026, F2-027, F2-028, F2-031, F2-034, F2-035, F2-036, F2-037, F2-038, F2-039, F2-040, F2-041, F2-042, F2-043, F2-044, F2-045, F2-046, F2-047, F2-048, F2-049, F3-001, F3-002, F3-003, F3-004, F3-005, F3-006, F3-007, F3-008, F3-009, F3-010, F3-011, F3-012, F3-013, F3-014, F3-015, F3-016, F3-017, F3-018, F3-019, F3-020, F3-021, F3-022, F3-023, F3-024, F3-025	Construction, operation and maintenance of the authorised development more than 9 metres beneath the surface
F3-026	Construction, operation and maintenance of the authorised development
F3-027, F3-027a, F3-028, F3-032	Construction, operation and maintenance of the authorised development more than 9 metres beneath the surface
F3-033, F3-041	Construction, operation and maintenance of the authorised development
F4-003, F4-004, F4-005	Construction, operation and maintenance of the authorised development more than 9 metres beneath the surface
F4-006, F4-007, F4-028, F4-117, F4-135, F4-141, F4-147, F4-148, F5-002, F5-004, F5-005, F5-007, F5-008, F5-008b, F5-008c, F5-009, F5-010, F5-011, F5-013, F5-014,	Construction, operation and maintenance of the authorised development

F5-015, F5-018, F5-019, F5-024, F5-028, F5-030, F5-032, F5-041, F5-042, F5-044, F5-047, F5-053, F5-055, F5-061, F5-061a, F5-066, F5-068, F5-072, F5-077	
---	--

Table 6.2: Compulsory Acquisition of rights

PART 1	
NATIONAL GRID	
COMPULSORY ACQUISITION OF RIGHTS (classes 3 and 4)	
No. on Plan	Purpose for which land may be acquired
A1-001, A1-002, A1-003, A1-004, A1-005, A1-006	Construction, operation and maintenance of the authorised development
A1-007	Access to land for the purpose of carrying out the authorised development including the power to carry out any ancillary works necessary to facilitate that access
A1-008, A1-009	Construction, operation and maintenance of the authorised development
A1-010	Access to land for the purpose of carrying out the authorised development including the power to carry out any ancillary works necessary to facilitate that access
A1-011, A1-012, A1-013, A1-014, A1-015, A1-016, A1-017, A1-018, A1-019, A1-020, A1-021, A1-022, A1-023	Construction, operation and maintenance of the authorised development
A1-024	Access to land for the purpose of carrying out the authorised development including the power to carry out any ancillary works necessary to facilitate that access
A1-025, A1-026, A1-027, A1-028, A1-029, A1-030, A1-031, A1-032, A1-033	Construction, operation and maintenance of the authorised development
A1-034	Access to land for the purpose of carrying out the authorised development including the power to carry out any ancillary works necessary to facilitate that access
A1-035	Construction, operation and maintenance of the authorised

	development
A1-036, A1-037	Access to land for the purpose of carrying out the authorised development including the power to carry out any ancillary works necessary to facilitate that access
A1-038, A1-038a, A1-039, A1-040, A1-041, A1-042, A1-043, A1-044, A1-045, A1-046, A1-047, A1-047a, A1-047b, A1-048, A1-048a, A1-048d, A1-049, A1-050, A1-051, A1-052, A1-053, A1-054, A1-055, A1-056, A1-056a, A1-056b, A1-057	Construction, operation and maintenance of the authorised development
A1-058, A1-059	Access to land for the purpose of carrying out the authorised development including the power to carry out any ancillary works necessary to facilitate that access
A1-060, A1-061, A1-062, A1-063, A1-064, A1-065, A1-065a, A1-066, A1-066a	Construction, operation and maintenance of the authorised development
A1-067	Access to land for the purpose of carrying out the authorised development including the power to carry out any ancillary works necessary to facilitate that access
A1-068	Construction, operation and maintenance of the authorised development
A1-069	Access to land for the purpose of carrying out the authorised development including the power to carry out any ancillary works necessary to facilitate that access
A1-070	Construction, operation and maintenance of the authorised development
A1-071, A1-072	Access to land for the purpose of carrying out the authorised development including the power to carry out any ancillary works necessary to facilitate that access
A1-073, A1-074, A1-075, A1-076, A1-077, A1-078, A1-079, A1-080, A1-081, A1-082, A1-083, A1-084, A1-085, A1-086, A1-087, A1-088, A1-089, A1-090, A1-091, A1-092, A1-095, A1-096	Construction, operation and maintenance of the authorised development
A1-097	Access to land for the purpose of

	carrying out the authorised development including the power to carry out any ancillary works necessary to facilitate that access
A1-098	Construction, operation and maintenance of the authorised development
A1-099, A1-100, A1-101, A1-102	Access to land for the purpose of carrying out the authorised development including the power to carry out any ancillary works necessary to facilitate that access
A1-103, A1-104	Construction, operation and maintenance of the authorised development
A1-105	Access to land for the purpose of carrying out the authorised development including the power to carry out any ancillary works necessary to facilitate that access
A1-106, A1-107, A1-108, A1-109, A2-001, A2-002, A2-003, A2-004, A2-005, A2-006, A2-007, A2-008, A2-009, A2-010, A2-011, A2-012, A2-013, A2-014, A2-015, A2-016, A2-017	Construction, operation and maintenance of the authorised development
A2-018, A2-019	Access to land for the purpose of carrying out the authorised development including the power to carry out any ancillary works necessary to facilitate that access
A2-020, A2-021, A2-022, A2-023, A2-024, A2-025, A2-026, A2-027, A2-028, A2-029, A2-030, A2-031, A2-032, A2-033, A2-034, A2-035, A2-036, A2-037, A2-038, A2-039, A2-040, A2-041, A2-042, A2-043, A2-044, A2-045, A2-046, A2-047, A2-048, A2-049, A2-050, A2-051, A2-052, A2-053, A2-054, A2-055, A2-056, A2-057	Construction, operation and maintenance of the authorised development
A2-058, A2-059	Access to land for the purpose of carrying out the authorised development including the power to carry out any ancillary works necessary to facilitate that access
A2-060, A2-061, A2-062, A2-063, A2-064, A2-065, A2-066, A2-067, A2-068, A2-069, A2-070, A2-071,	Construction, operation and maintenance of the authorised development

A2-072, A2-073, A2-074, A2-075, A2-076, A2-077, A2-078, A2-079, A2-080, A2-081, A2-082, A2-083, A2-084, A2-085, A2-086, A2-087, A2-088, A2-089	
A2-090, A2-091	Access to land for the purpose of carrying out the authorised development including the power to carry out any ancillary works necessary to facilitate that access
A2-092	Construction, operation and maintenance of the authorised development
A2-093	Access to land for the purpose of carrying out the authorised development including the power to carry out any ancillary works necessary to facilitate that access
A2-094, A2-095, A2-096, A2-097, A2-098, A2-099, A2-100, A2-101, A2-102, A2-103, A2-104, A2-105, A2-106, A2-107, A2-108, A3-001, A3-002, A3-003, A3-004, A3-005, A3-006, A3-007, A3-008, A3-009, A3-010, A3-011, A3-012, A3-013, A3-014, A3-015, A3-016, A3-017, A3-018, A3-019, A3-020, A3-021, A3-022, A3-023, A3-024, A3-025, A3-026, A3-027, A3-028, A3-029, A3-030, A3-031	Construction, operation and maintenance of the authorised development
A3-032	Access to land for the purpose of carrying out the authorised development including the power to carry out any ancillary works necessary to facilitate that access
A3-033, A3-034, A3-035, A3-036, A3-037, A3-038, A3-039, A3-040	Construction, operation and maintenance of the authorised development
A3-041	Access to land for the purpose of carrying out the authorised development including the power to carry out any ancillary works necessary to facilitate that access
A3-042, A3-043, A3-044, A3-045, A3-046, A3-047, A3-048, A3-049, A3-050, A3-051, A3-052, A3-053, A3-054, A3-055, A3-056, A3-057, A3-058, A3-059, A3-060	Construction, operation and maintenance of the authorised development
A3-061	Access to land for the purpose of

	carrying out the authorised development including the power to carry out any ancillary works necessary to facilitate that access
A3-062, A3-063	Construction, operation and maintenance of the authorised development
A3-064	Access to land for the purpose of carrying out the authorised development including the power to carry out any ancillary works necessary to facilitate that access
A3-065, A3-066, A3-067, A3-068, A3-069, A3-070, A3-071	Construction, operation and maintenance of the authorised development
A3-072	Access to land for the purpose of carrying out the authorised development including the power to carry out any ancillary works necessary to facilitate that access
A3-073, A3-074, A3-075	Construction, operation and maintenance of the authorised development
A3-076	Access to land for the purpose of carrying out the authorised development including the power to carry out any ancillary works necessary to facilitate that access
A3-077, A3-078, A3-079, A3-080, A3-081, A3-082, A3-083, A3-084, A3-085, A3-086, A3-087, A3-088	Construction, operation and maintenance of the authorised development
A3-089	Access to land for the purpose of carrying out the authorised development including the power to carry out any ancillary works necessary to facilitate that access
A3-090, A3-091	Construction, operation and maintenance of the authorised development
A3-092	Access to land for the purpose of carrying out the authorised development including the power to carry out any ancillary works necessary to facilitate that access
A3-093, A4-001, A4-002, A4-003	Construction, operation and maintenance of the authorised development
A4-004	Access to land for the purpose of carrying out the authorised development

	including the power to carry out any ancillary works necessary to facilitate that access
A4-005	Construction, operation and maintenance of the authorised development
A4-006	Access to land for the purpose of carrying out the authorised development including the power to carry out any ancillary works necessary to facilitate that access
A4-007, A4-008, A4-009, A4-010, A4-011	Construction, operation and maintenance of the authorised development
A4-012, A4-013	Access to land for the purpose of carrying out the authorised development including the power to carry out any ancillary works necessary to facilitate that access
A4-014, A4-015, A4-016, A4-017, A4-018, A4-019, A4-020, A4-021, A4-022, A4-023	Construction, operation and maintenance of the authorised development
A4-024	Access to land for the purpose of carrying out the authorised development including the power to carry out any ancillary works necessary to facilitate that access
A4-025, A4-026, A4-027	Construction, operation and maintenance of the authorised development
A4-028	Access to land for the purpose of carrying out the authorised development including the power to carry out any ancillary works necessary to facilitate that access
A4-029, A4-030	Construction, operation and maintenance of the authorised development
A4-031, A4-032, A4-033	Access to land for the purpose of carrying out the authorised development including the power to carry out any ancillary works necessary to facilitate that access
A4-035	Construction, operation and maintenance of the authorised development
A4-036, A4-038	Access to land for the purpose of carrying out the authorised development including the power to carry out any

	ancillary works necessary to facilitate that access
A4-039	Construction, operation and maintenance of the authorised development
A4-040, A4-041	Access to land for the purpose of carrying out the authorised development including the power to carry out any ancillary works necessary to facilitate that access
A4-042	Construction, operation and maintenance of the authorised development
A4-043, A4-044	Access to land for the purpose of carrying out the authorised development including the power to carry out any ancillary works necessary to facilitate that access
A4-045, A4-046, A5-001, A5-002, A5-003, A5-004, A5-005, A5-006, A5-007, A5-008, A5-009, A5-010, A5-011, A5-012, A5-013, A5-014, A5-015, A5-016, A5-017, A5-018, A5-019, A5-020, A5-021, A5-022, A5-023, A5-024, A5-025, A5-026, A5-027, A5-028, A5-029, A5-030, A5-031, A5-032, A5-033, A5-034, A5-035, A5-036, A5-037, A5-038	Construction, operation and maintenance of the authorised development
A5-039	Access to land for the purpose of carrying out the authorised development including the power to carry out any ancillary works necessary to facilitate that access
A5-040	Construction, operation and maintenance of the authorised development
A5-041	Access to land for the purpose of carrying out the authorised development including the power to carry out any ancillary works necessary to facilitate that access
A5-042, A5-043, A5-043a, A5-043b, A5-044, A5-044a, A5-045, A5-045a	Construction, operation and maintenance of the authorised development
A5-046	Access to land for the purpose of carrying out the authorised development including the power to carry out any ancillary works necessary to facilitate that access

B1-001, B1-001a, B1-002, B1-002a, B1-003, B1-003a, B1-004, B1-005	Construction, operation and maintenance of the authorised development
B1-006	Access to land for the purpose of carrying out the authorised development including the power to carry out any ancillary works necessary to facilitate that access
B1-007, B1-008, B1-009, B1-010, B1-011, B1-012, B1-013, B1-014, B1-015, B1-016, B1-017, B1-018, B1-019, B1-020, B1-021, B1-022, B1-023, B1-023a, B1-024, B1-025, B1-026, B1-027, B1-027a, B1-027b, B1-027c, B1-028, B1-029, B1-030, B1-031, B1-032, B1-033, B1-034, B1-035, B1-036, B1-037, B1-038, B1-039, B1-040, B1-041, B1-041a, B1-041b, B1-042, B1-043	Construction, operation and maintenance of the authorised development
B1-044, B1-045, B1-046	Access to land for the purpose of carrying out the authorised development including the power to carry out any ancillary works necessary to facilitate that access
B1-047, B1-048, B1-048a, B1-048b, B1-049, B1-050, B1-051	Construction, operation and maintenance of the authorised development
B1-052	Access to land for the purpose of carrying out the authorised development including the power to carry out any ancillary works necessary to facilitate that access
B1-053, B1-054, B1-055, B1-056	Construction, operation and maintenance of the authorised development
B1-057	Access to land for the purpose of carrying out the authorised development including the power to carry out any ancillary works necessary to facilitate that access
B1-058, B1-059, B1-060, B1-061, B1-062, B1-063, B1-064, B1-065	Construction, operation and maintenance of the authorised development
B1-066, B1-067	Access to land for the purpose of carrying out the authorised development including the power to carry out any ancillary works necessary to facilitate that access
B1-068	Construction, operation and

	maintenance of the authorised development
B1-069	Access to land for the purpose of carrying out the authorised development including the power to carry out any ancillary works necessary to facilitate that access
B1-070, B1-071, B1-072	Construction, operation and maintenance of the authorised development
B1-073	Access to land for the purpose of carrying out the authorised development including the power to carry out any ancillary works necessary to facilitate that access
B1-074, B1-075, B1-076, B1-077	Construction, operation and maintenance of the authorised development
B1-078, B1-079	Access to land for the purpose of carrying out the authorised development including the power to carry out any ancillary works necessary to facilitate that access
B1-080, B1-081, B1-082, B1-083, B1-084, B1-085, B1-086, B1-087, B1-088, B1-089	Construction, operation and maintenance of the authorised development
B1-090	Access to land for the purpose of carrying out the authorised development including the power to carry out any ancillary works necessary to facilitate that access
B1-091	Construction, operation and maintenance of the authorised development
B1-092	Access to land for the purpose of carrying out the authorised development including the power to carry out any ancillary works necessary to facilitate that access
B1-093, B1-094, B1-095, B1-096, B1-097, B1-098, B1-099, B1-100, B1-101, B1-102, B1-103, B1-104, B1-105, B1-106, B1-107, B1-108, B1-109, B1-110, B1-111, B1-113, B1-114, B1-115, B1-116, B1-117, B1-119, B1-120, B1-121, B1-122, B1-123, B1-124, B1-125, B2-001, B2-002, B2-003, B2-004, B2-005, B2-006, B2-007, B2-009, B2-010, B2-	Construction, operation and maintenance of the authorised development

011, B2-012	
B2-013	Access to land for the purpose of carrying out the authorised development including the power to carry out any ancillary works necessary to facilitate that access
B2-014, B2-015, B2-016, B2-017, B2-018, B2-019, B2-020, B2-021, B2-023, B2-024, B2-025, B2-026, B2-027, B2-028, B2-029, B2-030, B2-032, B2-033, B2-034, B2-035, B2-036, B2-037, B2-039, B2-040, B2-041, B2-042, B2-043, B2-044, B2-045, B2-046, B2-047, B2-048, B2-049, B2-050, B2-052, B2-053, B2-054, B2-055, B2-056, B2-057, B2-058, B2-059, B2-060, B2-061, B2-062, B2-063, B2-064, B2-065	Construction, operation and maintenance of the authorised development
B2-066, B2-068	Access to land for the purpose of carrying out the authorised development including the power to carry out any ancillary works necessary to facilitate that access
B2-069, B2-070	Construction, operation and maintenance of the authorised development
B2-071	Access to land for the purpose of carrying out the authorised development including the power to carry out any ancillary works necessary to facilitate that access
B2-072, B2-073, B2-074, B2-075, B2-076, B2-077, B2-077a, B2-078, B2-079, B2-080, B2-081, B2-082, B2-083, B2-084, B2-085, B2-086, B2-087, B2-088, B2-089, B2-090, B2-091, B2-092, B2-093, B2-094, B2-095	Construction, operation and maintenance of the authorised development
B2-096	Access to land for the purpose of carrying out the authorised development including the power to carry out any ancillary works necessary to facilitate that access
B2-097, B2-098, B2-099	Construction, operation and maintenance of the authorised development
B2-100, B2-101	Access to land for the purpose of carrying out the authorised development

	including the power to carry out any ancillary works necessary to facilitate that access
B2-102	Construction, operation and maintenance of the authorised development
B2-103, B2-104	Access to land for the purpose of carrying out the authorised development including the power to carry out any ancillary works necessary to facilitate that access
B2-105	Construction, operation and maintenance of the authorised development
B2-106	Access to land for the purpose of carrying out the authorised development including the power to carry out any ancillary works necessary to facilitate that access
B2-107, B2-108, B2-109, B2-110, B2-111, B2-112, B2-113, B2-114	Construction, operation and maintenance of the authorised development
B2-115	Access to land for the purpose of carrying out the authorised development including the power to carry out any ancillary works necessary to facilitate that access
B2-116, B2-117, B2-118	Construction, operation and maintenance of the authorised development
B2-119	Access to land for the purpose of carrying out the authorised development including the power to carry out any ancillary works necessary to facilitate that access
B2-120, B2-121	Construction, operation and maintenance of the authorised development
B2-122	Access to land for the purpose of carrying out the authorised development including the power to carry out any ancillary works necessary to facilitate that access
B2-123, B2-124, B2-125, B3-001, B3-002, B3-003, B3-004	Construction, operation and maintenance of the authorised development
B3-005	Access to land for the purpose of carrying out the authorised development including the power to carry out any

	ancillary works necessary to facilitate that access
B3-006, B3-007, B3-008	Construction, operation and maintenance of the authorised development
B3-009	Access to land for the purpose of carrying out the authorised development including the power to carry out any ancillary works necessary to facilitate that access
B3-010, B3-011	Construction, operation and maintenance of the authorised development
B3-012	Access to land for the purpose of carrying out the authorised development including the power to carry out any ancillary works necessary to facilitate that access
B3-013, B3-014	Construction, operation and maintenance of the authorised development
B3-015	Access to land for the purpose of carrying out the authorised development including the power to carry out any ancillary works necessary to facilitate that access
B3-016	Construction, operation and maintenance of the authorised development
B3-017, B3-018	Access to land for the purpose of carrying out the authorised development including the power to carry out any ancillary works necessary to facilitate that access
B3-019	Construction, operation and maintenance of the authorised development
B3-020	Access to land for the purpose of carrying out the authorised development including the power to carry out any ancillary works necessary to facilitate that access
B3-021, B3-022, B3-023	Construction, operation and maintenance of the authorised development
B3-024	Access to land for the purpose of carrying out the authorised development including the power to carry out any ancillary works necessary to facilitate

	that access
B3-025, B3-026, B3-027, B3-028, B3-029, B3-030	Construction, operation and maintenance of the authorised development
B3-031, B3-032	Access to land for the purpose of carrying out the authorised development including the power to carry out any ancillary works necessary to facilitate that access
B3-033, B3-034, B3-035, B3-036	Construction, operation and maintenance of the authorised development
B3-037	Access to land for the purpose of carrying out the authorised development including the power to carry out any ancillary works necessary to facilitate that access
B3-038, B3-039	Construction, operation and maintenance of the authorised development
B3-040	Access to land for the purpose of carrying out the authorised development including the power to carry out any ancillary works necessary to facilitate that access
B3-041, B3-042, B3-043	Construction, operation and maintenance of the authorised development
B3-044	Access to land for the purpose of carrying out the authorised development including the power to carry out any ancillary works necessary to facilitate that access
B3-045, B3-046, B3-047	Construction, operation and maintenance of the authorised development
B3-048	Access to land for the purpose of carrying out the authorised development including the power to carry out any ancillary works necessary to facilitate that access
B3-049, B3-050, B3-051, B3-052, B3-053	Construction, operation and maintenance of the authorised development
B3-054	Access to land for the purpose of carrying out the authorised development including the power to carry out any ancillary works necessary to facilitate that access

B3-055	Construction, operation and maintenance of the authorised development
B3-056	Access to land for the purpose of carrying out the authorised development including the power to carry out any ancillary works necessary to facilitate that access
B3-057, B3-058, B3-059	Construction, operation and maintenance of the authorised development
B3-060	Access to land for the purpose of carrying out the authorised development including the power to carry out any ancillary works necessary to facilitate that access
B3-061, B3-062, B3-063	Construction, operation and maintenance of the authorised development
B3-064	Access to land for the purpose of carrying out the authorised development including the power to carry out any ancillary works necessary to facilitate that access
B3-065, B3-066, B3-067, B3-068, B3-069, B3-070, B3-071, B3-072, B3-073, B3-074, B3-075, B3-076, B3-077, B3-078, B3-079	Construction, operation and maintenance of the authorised development
B3-080	Access to land for the purpose of carrying out the authorised development including the power to carry out any ancillary works necessary to facilitate that access
B3-081, B3-082, B3-083, B3-084, B3-085, B3-086, B3-087, B3-088, B3-089, B3-090, B3-091, B3-092, B3-093, B3-094	Construction, operation and maintenance of the authorised development
B3-095	Access to land for the purpose of carrying out the authorised development including the power to carry out any ancillary works necessary to facilitate that access
B3-096, B3-097, B3-098, B3-099, B3-100	Construction, operation and maintenance of the authorised development
B3-101, B3-102	Access to land for the purpose of carrying out the authorised development including the power to carry out any ancillary works necessary to facilitate

	that access
B3-103, B3-104	Construction, operation and maintenance of the authorised development
B3-105, B3-106	Access to land for the purpose of carrying out the authorised development including the power to carry out any ancillary works necessary to facilitate that access
B3-107	Construction, operation and maintenance of the authorised development
B3-108	Access to land for the purpose of carrying out the authorised development including the power to carry out any ancillary works necessary to facilitate that access
B3-109, B3-110, B3-111	Construction, operation and maintenance of the authorised development
B3-112	Access to land for the purpose of carrying out the authorised development including the power to carry out any ancillary works necessary to facilitate that access
B3-113, B3-114	Construction, operation and maintenance of the authorised development
B3-115, B3-116	Access to land for the purpose of carrying out the authorised development including the power to carry out any ancillary works necessary to facilitate that access
B3-117	Construction, operation and maintenance of the authorised development
B3-118, B3-119, B4-001, B4-002	Access to land for the purpose of carrying out the authorised development including the power to carry out any ancillary works necessary to facilitate that access
B4-003, B4-004, B4-005, B4-006	Construction, operation and maintenance of the authorised development
B4-007	Access to land for the purpose of carrying out the authorised development including the power to carry out any ancillary works necessary to facilitate that access

B4-008, B4-010, B4-011	Construction, operation and maintenance of the authorised development
B4-012	Access to land for the purpose of carrying out the authorised development including the power to carry out any ancillary works necessary to facilitate that access
B4-013	Construction, operation and maintenance of the authorised development
B4-014	Access to land for the purpose of carrying out the authorised development including the power to carry out any ancillary works necessary to facilitate that access
B4-015, B4-016	Construction, operation and maintenance of the authorised development
B4-017	Access to land for the purpose of carrying out the authorised development including the power to carry out any ancillary works necessary to facilitate that access
B4-019, B4-020, B4-021, B4-022, B4-023, B4-024	Construction, operation and maintenance of the authorised development
B4-025	Access to land for the purpose of carrying out the authorised development including the power to carry out any ancillary works necessary to facilitate that access
B4-026, B4-027, B4-028, B4-029, B4-030, B4-031, B4-032, B4-033, B4-034, B4-035, B4-036, B4-037, B4-038	Construction, operation and maintenance of the authorised development
B4-039	Access to land for the purpose of carrying out the authorised development including the power to carry out any ancillary works necessary to facilitate that access
B4-040, B4-041, B4-042, B4-043, B4-044, B4-045, B4-046, B4-047, B4-048, B4-049, B4-050, B4-051, B4-052, B4-053, B4-054, B4-055	Construction, operation and maintenance of the authorised development
B4-056	Access to land for the purpose of carrying out the authorised development including the power to carry out any ancillary works necessary to facilitate

	that access
B4-057, B4-058, B4-059	Construction, operation and maintenance of the authorised development
B4-060	Access to land for the purpose of carrying out the authorised development including the power to carry out any ancillary works necessary to facilitate that access
B4-061, B4-062, B4-063	Construction, operation and maintenance of the authorised development
B4-064	Access to land for the purpose of carrying out the authorised development including the power to carry out any ancillary works necessary to facilitate that access
B4-065, B4-066, B4-067	Construction, operation and maintenance of the authorised development
CA1-001	Access to land for the purpose of carrying out the authorised development including the power to carry out any ancillary works necessary to facilitate that access
CA1-002, CA1-003, CA1-004, CA1-005, CA1-006, CA1-007, CA1-008, CA1-009, CA1-010	Construction, operation and maintenance of the authorised development
CA1-011, CA1-012	Access to land for the purpose of carrying out the authorised development including the power to carry out any ancillary works necessary to facilitate that access
CA1-013, CA1-014, CA1-015, CA1-016, CA1-017, CA1-018, CA1-019, CA1-020	Construction, operation and maintenance of the authorised development
CA1-021	Access to land for the purpose of carrying out the authorised development including the power to carry out any ancillary works necessary to facilitate that access
CA1-022	Construction, operation and maintenance of the authorised development
CA1-023	Access to land for the purpose of carrying out the authorised development including the power to carry out any ancillary works necessary to facilitate that access

CA1-024, CA1-025, CA1-026, CA1-027, CA1-028, CA1-029, CA1-030	Construction, operation and maintenance of the authorised development
CA1-031	Access to land for the purpose of carrying out the authorised development including the power to carry out any ancillary works necessary to facilitate that access
CA1-032, CA1-033, CA1-034, CA1-035, CA1-036, CA1-037, CA1-038, CA1-039, CA1-040, CA1-041, CA1-042, CA1-043, CA1-044, CA1-045, CA1-046	Construction, operation and maintenance of the authorised development
CA1-047, CA1-048	Access to land for the purpose of carrying out the authorised development including the power to carry out any ancillary works necessary to facilitate that access
CA2-001	Construction, operation and maintenance of the authorised development
CA2-002	Access to land for the purpose of carrying out the authorised development including the power to carry out any ancillary works necessary to facilitate that access
CA2-003, CA2-004, CA2-005	Construction, operation and maintenance of the authorised development
CA2-006, CA2-007	Access to land for the purpose of carrying out the authorised development including the power to carry out any ancillary works necessary to facilitate that access
CA2-008, CA2-009, CA2-010, CA2-011, CA2-012, CA2-013, CA2-014, CA2-015, CA2-016, CA2-017	Construction, operation and maintenance of the authorised development
CA2-018	Access to land for the purpose of carrying out the authorised development including the power to carry out any ancillary works necessary to facilitate that access
CA2-019	Construction, operation and maintenance of the authorised development
CA2-020	Access to land for the purpose of carrying out the authorised development including the power to carry out any ancillary works necessary to facilitate that access

CA2-021	Construction, operation and maintenance of the authorised development
CA2-022, CA2-023	Access to land for the purpose of carrying out the authorised development including the power to carry out any ancillary works necessary to facilitate that access
CA2-024	Construction, operation and maintenance of the authorised development
CA2-025, CA2-026	Access to land for the purpose of carrying out the authorised development including the power to carry out any ancillary works necessary to facilitate that access
CA2-027, CA2-028, CA2-029, CA2-030, CA2-031, CA2-032, CA2-033, CA2-034, CA2-035, CA2-036, CA2-037, CA2-038, CA2-039	Construction, operation and maintenance of the authorised development
CA2-040	Access to land for the purpose of carrying out the authorised development including the power to carry out any ancillary works necessary to facilitate that access
CA2-041	Construction, operation and maintenance of the authorised development
CA2-042	Access to land for the purpose of carrying out the authorised development including the power to carry out any ancillary works necessary to facilitate that access
CA2-043	Construction, operation and maintenance of the authorised development
CA2-044	Access to land for the purpose of carrying out the authorised development including the power to carry out any ancillary works necessary to facilitate that access
CA2-045, CA2-046	Construction, operation and maintenance of the authorised development
CA2-047	Access to land for the purpose of carrying out the authorised development including the power to carry out any ancillary works necessary to facilitate that access

CA2-048, CA2-049, CA2-050, CA2-051, CA2-052, CA2-053, CA2-054, CA2-055, CA2-056, CA2-057, CA2-058, CA2-059, CA2-060, CA2-061, CA2-062, CA2-063, CA2-064, CA2-065	Construction, operation and maintenance of the authorised development
CA2-066, CA2-067, CA2-068	Access to land for the purpose of carrying out the authorised development including the power to carry out any ancillary works necessary to facilitate that access
CA2-069, CA2-070	Construction, operation and maintenance of the authorised development
CA2-071, CA2-072, CA2-073	Access to land for the purpose of carrying out the authorised development including the power to carry out any ancillary works necessary to facilitate that access
CA2-074	Construction, operation and maintenance of the authorised development
CA2-075, CA2-076	Access to land for the purpose of carrying out the authorised development including the power to carry out any ancillary works necessary to facilitate that access
CA2-077	Construction, operation and maintenance of the authorised development
CA2-078, CA2-079	Access to land for the purpose of carrying out the authorised development including the power to carry out any ancillary works necessary to facilitate that access
CA2-080, CA2-081, CA2-082, CA2-083, CA2-084, CA2-085, CA2-086, CA2-087, CA2-088, CA2-089, CA2-090, CA2-091, CA2-092, CA2-093, CA2-094, CA2-095, CA2-096, CA2-097, CA2-098, CA2-099, CA2-100, CA2-101, CA2-101a, CA2-102, CA2-103, CA2-104, CA2-105, CA2-106, CA2-106a, CA2-107, CA2-108, CA2-109, CA2-110, CA2-111, CA2-112, CA2-113, CA2-114, CA2-115	Construction, operation and maintenance of the authorised development
CA2-116	Access to land for the purpose of carrying out the authorised development including the power to carry out any ancillary works necessary to facilitate that access

CA2-117, CA2-118, CA2-119, CA2-120, CA2-121, CA2-122, CA2-123, CA2-124, CA2-125, CA2-125a, CA2-126, CA2-127, CA2-128, CA2-129	Construction, operation and maintenance of the authorised development
CA2-130	Access to land for the purpose of carrying out the authorised development including the power to carry out any ancillary works necessary to facilitate that access
CA2-131, CA2-132, CA2-133, CA3-001, CA3-002, CA3-003, CA3-004, CA3-005, CA3-006, CA3-007, CA3-008, CA3-009, CA3-010	Construction, operation and maintenance of the authorised development
CA3-011	Access to land for the purpose of carrying out the authorised development including the power to carry out any ancillary works necessary to facilitate that access
CA3-012, CA3-013	Construction, operation and maintenance of the authorised development
CA3-014	Access to land for the purpose of carrying out the authorised development including the power to carry out any ancillary works necessary to facilitate that access
CA3-015, CA3-016, CA3-017, CA3-018, CA3-019, CA3-020, CA3-021, CA3-022, CA3-023	Construction, operation and maintenance of the authorised development
CA3-024, CA3-025, CA3-026	Access to land for the purpose of carrying out the authorised development including the power to carry out any ancillary works necessary to facilitate that access
CA3-027, CA3-028, CA3-028a, CA3-029, CA3-030, CA3-031, CA3-032, CA3-032a, CA3-033, CA3-034, CA3-035, CA3-036, CA3-037, CA3-038, CA3-039, CA3-040, CA3-041, CA3-042, CA3-043, CA3-044, CA3-045, CA3-046, CA3-047, CA3-048, CA3-049, CA4-001, CA4-002, CA4-003, CA4-004, CA4-005, CA4-006, CA4-007, CA4-008, CA4-009, CA4-010	Construction, operation and maintenance of the authorised development
CA4-011	Access to land for the purpose of carrying out the authorised development including the power to carry out any ancillary works necessary to facilitate that access

CA4-012	Construction, operation and maintenance of the authorised development
CA4-013, CA4-014, CA4-015, CA4-016	Access to land for the purpose of carrying out the authorised development including the power to carry out any ancillary works necessary to facilitate that access
CA4-017	Construction, operation and maintenance of the authorised development
CA4-018	Access to land for the purpose of carrying out the authorised development including the power to carry out any ancillary works necessary to facilitate that access
CA4-019, CA4-020	Construction, operation and maintenance of the authorised development
CA4-021, CA4-022, CA4-023, CA4-024	Access to land for the purpose of carrying out the authorised development including the power to carry out any ancillary works necessary to facilitate that access
CA4-026, CA4-027, CA4-027a, CA4-027b	Construction, operation and maintenance of the authorised development
CA4-028, CA4-029, CA4-030	Access to land for the purpose of carrying out the authorised development including the power to carry out any ancillary works necessary to facilitate that access
CA4-031	Construction, operation and maintenance of the authorised development
CA4-032	Access to land for the purpose of carrying out the authorised development including the power to carry out any ancillary works necessary to facilitate that access
CA4-033	Construction, operation and maintenance of the authorised development
CA4-034	Access to land for the purpose of carrying out the authorised development including the power to carry out any ancillary works necessary to facilitate that access
CA4-035, CA4-036, CA4-037	Construction, operation and

	maintenance of the authorised development
CA4-038	Access to land for the purpose of carrying out the authorised development including the power to carry out any ancillary works necessary to facilitate that access
CA4-039	Construction, operation and maintenance of the authorised development
CA4-040	Access to land for the purpose of carrying out the authorised development including the power to carry out any ancillary works necessary to facilitate that access
CA4-041	Construction, operation and maintenance of the authorised development
CA4-042	Access to land for the purpose of carrying out the authorised development including the power to carry out any ancillary works necessary to facilitate that access
CA4-043, CA4-044	Construction, operation and maintenance of the authorised development
CA4-045	Access to land for the purpose of carrying out the authorised development including the power to carry out any ancillary works necessary to facilitate that access
CA4-046, CA4-047, CA4-048, CA4-049, CA4-050, CA4-051, CA4-052, CA4-053, CA4-054, CA4-055, CA4-056, CA4-057	Construction, operation and maintenance of the authorised development
CA4-058, CA5-001	Access to land for the purpose of carrying out the authorised development including the power to carry out any ancillary works necessary to facilitate that access
CA5-002, CA5-002a, CA5-003	Construction, operation and maintenance of the authorised development
CA5-004	Access to land for the purpose of carrying out the authorised development including the power to carry out any ancillary works necessary to facilitate that access
CA5-005	Construction, operation and maintenance of the authorised

	development
CA5-006	Access to land for the purpose of carrying out the authorised development including the power to carry out any ancillary works necessary to facilitate that access
CA5-007, CA5-008, CA5-009, CA5-010, CA5-011, CA5-012, CA5-013	Construction, operation and maintenance of the authorised development
CA5-014	Access to land for the purpose of carrying out the authorised development including the power to carry out any ancillary works necessary to facilitate that access
CA5-015, CA5-015a, CA5-016, CA5-017	Construction, operation and maintenance of the authorised development
CA5-018	Access to land for the purpose of carrying out the authorised development including the power to carry out any ancillary works necessary to facilitate that access
CA5-019	Construction, operation and maintenance of the authorised development
CA5-020, CA5-021, CA5-022	Access to land for the purpose of carrying out the authorised development including the power to carry out any ancillary works necessary to facilitate that access
CA5-023	Construction, operation and maintenance of the authorised development
CA5-024	Access to land for the purpose of carrying out the authorised development including the power to carry out any ancillary works necessary to facilitate that access
CA5-025, CA5-026, CA5-027, CA5-028, CA5-029	Construction, operation and maintenance of the authorised development
CA5-030	Access to land for the purpose of carrying out the authorised development including the power to carry out any ancillary works necessary to facilitate that access
CA5-031, CA6-001, CA6-002	Construction, operation and maintenance of the authorised development

CA6-003	Access to land for the purpose of carrying out the authorised development including the power to carry out any ancillary works necessary to facilitate that access
CA6-004, CA6-005, CA6-006, CA6-007, CA6-008	Construction, operation and maintenance of the authorised development
CA6-009	Access to land for the purpose of carrying out the authorised development including the power to carry out any ancillary works necessary to facilitate that access
CA6-010	Construction, operation and maintenance of the authorised development
CA7-001	Access to land for the purpose of carrying out the authorised development including the power to carry out any ancillary works necessary to facilitate that access
CA7-002	Construction, operation and maintenance of the authorised development
CA7-003, CA7-004	Access to land for the purpose of carrying out the authorised development including the power to carry out any ancillary works necessary to facilitate that access
CA7-005, CA7-006, CA7-007, CA7-008, CA7-009	Construction, operation and maintenance of the authorised development
CA7-010, CA7-011, CA7-012	Access to land for the purpose of carrying out the authorised development including the power to carry out any ancillary works necessary to facilitate that access
CA7-013, CA7-014	Construction, operation and maintenance of the authorised development
CA7-015	Access to land for the purpose of carrying out the authorised development including the power to carry out any ancillary works necessary to facilitate that access
CA7-016, CA7-017, CA7-018, CA7-019, CA7-020, CA7-021, CA7-022, CA7-023, CA7-024, CA7-025, CA7-026, CA7-027, CA7-028, CA7-029, CA7-030, CA7-033,	Construction, operation and maintenance of the authorised development

CA7-036, CA7-037, CA7-039, CA7-040, CA7-042, CA7-042a, CA7-043, CA7-044, CA7-045, CA7-047, CA7-049, CA7-050, CA7-050a, CA7-054, CA7-055, CA7-055a	
CA7-056	Access to land for the purpose of carrying out the authorised development including the power to carry out any ancillary works necessary to facilitate that access
CA7-058	Construction, operation and maintenance of the authorised development
CA7-060	Access to land for the purpose of carrying out the authorised development including the power to carry out any ancillary works necessary to facilitate that access
CA7-061, CA7-061a, CA7-061b, CA7-061c, CA7-064	Construction, operation and maintenance of the authorised development
CA7-065	Access to land for the purpose of carrying out the authorised development including the power to carry out any ancillary works necessary to facilitate that access
CA7-066	Construction, operation and maintenance of the authorised development
CA7-067	Access to land for the purpose of carrying out the authorised development including the power to carry out any ancillary works necessary to facilitate that access
CA7-068, CA7-069, CA7-070, CA7-071	Construction, operation and maintenance of the authorised development
CA7-072, CA7-073, CA7-074, CA7-075, CA7-076	Access to land for the purpose of carrying out the authorised development including the power to carry out any ancillary works necessary to facilitate that access
CA7-077, CA7-078	Construction, operation and maintenance of the authorised development
CA7-079	Access to land for the purpose of carrying out the authorised development including the power to carry out any ancillary works necessary to facilitate

	that access
CA7-080, CA7-081	Construction, operation and maintenance of the authorised development
CB1-001	Access to land for the purpose of carrying out the authorised development including the power to carry out any ancillary works necessary to facilitate that access
CB1-002, CB1-003, CB1-004, CB1-005, CB1-006, CB1-007, CB1-008, CB1-009, CB1-010	Construction, operation and maintenance of the authorised development
CB1-011, CB1-012	Access to land for the purpose of carrying out the authorised development including the power to carry out any ancillary works necessary to facilitate that access
CB1-013, CB1-014, CB1-015, CB1-016, CB1-017, CB1-018, CB1-019, CB1-020	Construction, operation and maintenance of the authorised development
CB1-021	Access to land for the purpose of carrying out the authorised development including the power to carry out any ancillary works necessary to facilitate that access
CB1-022	Construction, operation and maintenance of the authorised development
CB1-023	Access to land for the purpose of carrying out the authorised development including the power to carry out any ancillary works necessary to facilitate that access
CB1-024, CB1-025, CB1-026, CB1-027, CB1-028, CB1-029, CB1-030	Construction, operation and maintenance of the authorised development
CB1-031	Access to land for the purpose of carrying out the authorised development including the power to carry out any ancillary works necessary to facilitate that access
CB1-032, CB1-033, CB1-034, CB1-035, CB1-036, CB1-037, CB1-038, CB1-039, CB1-040, CB1-041, CB1-042, CB1-043, CB1-044, CB1-045, CB1-046	Construction, operation and maintenance of the authorised development
CB1-047, CB1-048	Access to land for the purpose of carrying out the authorised development including the power to carry out any ancillary works necessary to facilitate

	that access
CB2-001	Construction, operation and maintenance of the authorised development
CB2-002	Access to land for the purpose of carrying out the authorised development including the power to carry out any ancillary works necessary to facilitate that access
CB2-003, CB2-004, CB2-005	Construction, operation and maintenance of the authorised development
CB2-006, CB2-007	Access to land for the purpose of carrying out the authorised development including the power to carry out any ancillary works necessary to facilitate that access
CB2-008, CB2-009, CB2-010, CB2-011, CB2-012, CB2-013, CB2-014, CB2-015, CB2-016, CB2-017	Construction, operation and maintenance of the authorised development
CB2-018	Access to land for the purpose of carrying out the authorised development including the power to carry out any ancillary works necessary to facilitate that access
CB2-019	Construction, operation and maintenance of the authorised development
CB2-020	Access to land for the purpose of carrying out the authorised development including the power to carry out any ancillary works necessary to facilitate that access
CB2-021	Construction, operation and maintenance of the authorised development
CB2-022, CB2-023	Access to land for the purpose of carrying out the authorised development including the power to carry out any ancillary works necessary to facilitate that access
CB2-024	Construction, operation and maintenance of the authorised development
CB2-025, CB2-026	Access to land for the purpose of carrying out the authorised development including the power to carry out any ancillary works necessary to facilitate that access

CB2-027, CB2-028, CB2-029, CB2-030, CB2-031, CB2-032, CB2-033, CB2-034, CB2-035, CB2-036, CB2-037, CB2-038, CB2-039	Construction, operation and maintenance of the authorised development
CB2-040	Access to land for the purpose of carrying out the authorised development including the power to carry out any ancillary works necessary to facilitate that access
CB2-041	Construction, operation and maintenance of the authorised development
CB2-042	Access to land for the purpose of carrying out the authorised development including the power to carry out any ancillary works necessary to facilitate that access
CB2-043	Construction, operation and maintenance of the authorised development
CB2-044	Access to land for the purpose of carrying out the authorised development including the power to carry out any ancillary works necessary to facilitate that access
CB2-045, CB2-046	Construction, operation and maintenance of the authorised development
CB2-047	Access to land for the purpose of carrying out the authorised development including the power to carry out any ancillary works necessary to facilitate that access
CB2-048, CB2-049, CB2-050, CB2-051, CB2-052, CB2-053, CB2-054, CB2-055, CB2-056, CB2-057, CB2-058, CB2-059, CB2-060, CB2-061, CB2-062, CB2-063, CB2-064, CB2-065	Construction, operation and maintenance of the authorised development
CB2-066, CB2-067, CB2-068	Access to land for the purpose of carrying out the authorised development including the power to carry out any ancillary works necessary to facilitate that access
CB2-069, CB2-070	Construction, operation and maintenance of the authorised development
CB2-071, CB2-072, CB2-073	Access to land for the purpose of carrying out the authorised development including the power to carry out any

	ancillary works necessary to facilitate that access
CB2-074	Construction, operation and maintenance of the authorised development
CB2-075, CB2-076	Access to land for the purpose of carrying out the authorised development including the power to carry out any ancillary works necessary to facilitate that access
CB2-077	Construction, operation and maintenance of the authorised development
CB2-078, CB2-079	Access to land for the purpose of carrying out the authorised development including the power to carry out any ancillary works necessary to facilitate that access
CB2-080, CB2-081, CB2-082, CB2-083, CB2-084, CB2-085, CB2-086, CB2-087, CB2-088, CB2-089, CB2-090, CB2-091, CB2-092, CB2-093, CB2-094, CB2-095, CB2-096, CB2-097, CB2-098, CB2-099, CB2-100, CB2-101, CB2-101a, CB2-102, CB2-103, CB2-104, CB2-105, CB2-106, CB2-106a, CB2-107, CB2-108, CB2-109, CB2-110, CB2-111, CB2-112, CB2-113, CB2-114, CB2-115	Construction, operation and maintenance of the authorised development
CB2-116	Access to land for the purpose of carrying out the authorised development including the power to carry out any ancillary works necessary to facilitate that access
CB2-117, CB2-118, CB2-119, CB2-120, CB2-121, CB2-122, CB2-123, CB2-124, CB2-125, CB2-125a, CB2-126, CB2-127, CB2-128, CB2-129	Construction, operation and maintenance of the authorised development
CB2-130	Access to land for the purpose of carrying out the authorised development including the power to carry out any ancillary works necessary to facilitate that access
CB2-131, CB2-132, CB2-133, CB3-001, CB3-002, CB3-003, CB3-004, CB3-005, CB3-006, CB3-007, CB3-008, CB3-009, CB3-010	Construction, operation and maintenance of the authorised development
CB3-011	Access to land for the purpose of carrying out the authorised development including the power to carry out any

	ancillary works necessary to facilitate that access
CB3-012, CB3-013	Construction, operation and maintenance of the authorised development
CB3-014	Access to land for the purpose of carrying out the authorised development including the power to carry out any ancillary works necessary to facilitate that access
CB3-015, CB3-016, CB3-017, CB3-018, CB3-019, CB3-020, CB3-021, CB3-022, CB3-023	Construction, operation and maintenance of the authorised development
CB3-024, CB3-025, CB3-026	Access to land for the purpose of carrying out the authorised development including the power to carry out any ancillary works necessary to facilitate that access
CB3-027, CB3-028, CB3-028a, CB3-029, CB3-030, CB3-031, CB3-032, CB3-032a, CB3-033, CB3-034, CB3-035, CB3-036, CB3-037, CB3-038, CB3-039, CB3-040, CB3-041, CB3-042, CB3-043, CB3-044, CB3-045, CB3-046, CB3-047, CB3-048, CB3-049, CB4-001, CB4-002, CB4-003, CB4-004, CB4-005, CB4-006, CB4-007, CB4-008, CB4-009, CB4-010	Construction, operation and maintenance of the authorised development
CB4-011	Access to land for the purpose of carrying out the authorised development including the power to carry out any ancillary works necessary to facilitate that access
CB4-012	Construction, operation and maintenance of the authorised development
CB4-013, CB4-014, CB4-015, CB4-016	Access to land for the purpose of carrying out the authorised development including the power to carry out any ancillary works necessary to facilitate that access
CB4-017	Construction, operation and maintenance of the authorised development
CB4-018	Access to land for the purpose of carrying out the authorised development including the power to carry out any ancillary works necessary to facilitate that access

CB4-019, CB4-020	Construction, operation and maintenance of the authorised development
CB4-021, CB4-022, CB4-023, CB4-024	Access to land for the purpose of carrying out the authorised development including the power to carry out any ancillary works necessary to facilitate that access
CB4-025, CB4-026, CB4-026a, CB4-026b	Construction, operation and maintenance of the authorised development
CB4-027, CB4-028, CB4-029	Access to land for the purpose of carrying out the authorised development including the power to carry out any ancillary works necessary to facilitate that access
CB4-030	Construction, operation and maintenance of the authorised development
CB4-031	Access to land for the purpose of carrying out the authorised development including the power to carry out any ancillary works necessary to facilitate that access
CB4-032	Construction, operation and maintenance of the authorised development
CB4-033	Access to land for the purpose of carrying out the authorised development including the power to carry out any ancillary works necessary to facilitate that access
CB4-034, CB4-035, CB4-036	Construction, operation and maintenance of the authorised development
CB4-037	Access to land for the purpose of carrying out the authorised development including the power to carry out any ancillary works necessary to facilitate that access
CB4-038	Construction, operation and maintenance of the authorised development
CB4-039	Access to land for the purpose of carrying out the authorised development including the power to carry out any ancillary works necessary to facilitate that access
CB4-040	Construction, operation and

	maintenance of the authorised development
CB4-041	Access to land for the purpose of carrying out the authorised development including the power to carry out any ancillary works necessary to facilitate that access
CB4-042, CB4-043	Construction, operation and maintenance of the authorised development
CB4-044	Access to land for the purpose of carrying out the authorised development including the power to carry out any ancillary works necessary to facilitate that access
CB4-045, CB4-046, CB4-047, CB4-048, CB4-049, CB4-050, CB4-051, CB4-052, CB4-053, CB4-054, CB4-055, CB4-056	Construction, operation and maintenance of the authorised development
CB4-057, CB5-001	Access to land for the purpose of carrying out the authorised development including the power to carry out any ancillary works necessary to facilitate that access
CB5-002, CB5-002a, CB5-003	Construction, operation and maintenance of the authorised development
CB5-004	Access to land for the purpose of carrying out the authorised development including the power to carry out any ancillary works necessary to facilitate that access
CB5-005	Construction, operation and maintenance of the authorised development
CB5-006	Access to land for the purpose of carrying out the authorised development including the power to carry out any ancillary works necessary to facilitate that access
CB5-007, CB5-008, CB5-009, CB5-010, CB5-011, CB5-012, CB5-013	Construction, operation and maintenance of the authorised development
CB5-014	Access to land for the purpose of carrying out the authorised development including the power to carry out any ancillary works necessary to facilitate that access
CB5-015, CB5-015a, CB5-016, CB5-017	Construction, operation and maintenance of the authorised

	development
CB5-018	Access to land for the purpose of carrying out the authorised development including the power to carry out any ancillary works necessary to facilitate that access
CB5-019	Construction, operation and maintenance of the authorised development
CB5-020, CB5-021, CB5-022	Access to land for the purpose of carrying out the authorised development including the power to carry out any ancillary works necessary to facilitate that access
CB5-023	Construction, operation and maintenance of the authorised development
CB5-024	Access to land for the purpose of carrying out the authorised development including the power to carry out any ancillary works necessary to facilitate that access
CB5-025, CB5-026, CB5-027, CB5-028, CB5-029	Construction, operation and maintenance of the authorised development
CB5-030	Access to land for the purpose of carrying out the authorised development including the power to carry out any ancillary works necessary to facilitate that access
CB5-031, CB6-001, CB6-002	Construction, operation and maintenance of the authorised development
CB6-003	Access to land for the purpose of carrying out the authorised development including the power to carry out any ancillary works necessary to facilitate that access
CB6-004, CB6-005, CB6-006, CB6-007, CB6-008	Construction, operation and maintenance of the authorised development
CB6-009, CB6-010, CB7-001	Access to land for the purpose of carrying out the authorised development including the power to carry out any ancillary works necessary to facilitate that access
CB7-002	Construction, operation and maintenance of the authorised development

CB7-003, CB7-004	Access to land for the purpose of carrying out the authorised development including the power to carry out any ancillary works necessary to facilitate that access
CB7-005, CB7-006, CB7-007, CB7-008, CB7-009	Construction, operation and maintenance of the authorised development
CB7-010, CB7-011, CB7-012	Access to land for the purpose of carrying out the authorised development including the power to carry out any ancillary works necessary to facilitate that access
CB7-013, CB7-014	Construction, operation and maintenance of the authorised development
CB7-015	Access to land for the purpose of carrying out the authorised development including the power to carry out any ancillary works necessary to facilitate that access
CB7-016, CB7-017, CB7-018, CB7-019, CB7-020, CB7-021, CB7-022, CB7-023, CB7-024, CB7-025, CB7-026, CB7-027, CB7-028, CB7-029, CB7-030, CB7-033, CB7-036, CB7-037, CB7-039, CB7-040, CB7-042, CB7-042a, CB7-043, CB7-044, CB7-045, CB7-045a, CB7-045b, CB7-048, CB7-048a, CB7-049	Construction, operation and maintenance of the authorised development
CB7-051	Access to land for the purpose of carrying out the authorised development including the power to carry out any ancillary works necessary to facilitate that access
CB7-053	Construction, operation and maintenance of the authorised development
CB7-055	Access to land for the purpose of carrying out the authorised development including the power to carry out any ancillary works necessary to facilitate that access
CB7-056, CB7-056a, CB7-056b, CB7-056c, CB7-058, CB7-058a, CB7-059	Construction, operation and maintenance of the authorised development
CB7-060	Access to land for the purpose of carrying out the authorised development including the power to carry out any

	ancillary works necessary to facilitate that access
CB7-061	Construction, operation and maintenance of the authorised development
CB7-062	Access to land for the purpose of carrying out the authorised development including the power to carry out any ancillary works necessary to facilitate that access
CB7-063, CB7-064, CB7-065, CB7-066	Construction, operation and maintenance of the authorised development
CB7-067, CB7-068, CB7-069, CB7-070, CB7-071	Access to land for the purpose of carrying out the authorised development including the power to carry out any ancillary works necessary to facilitate that access
CB7-072, CB7-073	Construction, operation and maintenance of the authorised development
CB7-074	Access to land for the purpose of carrying out the authorised development including the power to carry out any ancillary works necessary to facilitate that access
CB7-075, CB7-076	Construction, operation and maintenance of the authorised development
DA1-001	Access to land for the purpose of carrying out the authorised development including the power to carry out any ancillary works necessary to facilitate that access
DA1-002	Construction, operation and maintenance of the authorised development
DA1-003, DA1-004	Access to land for the purpose of carrying out the authorised development including the power to carry out any ancillary works necessary to facilitate that access
DA1-005	Construction, operation and maintenance of the authorised development
DA1-006	Access to land for the purpose of carrying out the authorised development including the power to carry out any ancillary works necessary to facilitate

	that access
DA1-007	Construction, operation and maintenance of the authorised development
DA1-008	Access to land for the purpose of carrying out the authorised development including the power to carry out any ancillary works necessary to facilitate that access
DA1-009	Construction, operation and maintenance of the authorised development
DA1-010	Access to land for the purpose of carrying out the authorised development including the power to carry out any ancillary works necessary to facilitate that access
DA1-011	Construction, operation and maintenance of the authorised development
DA1-012	Access to land for the purpose of carrying out the authorised development including the power to carry out any ancillary works necessary to facilitate that access
DA1-013, DA1-014, DA1-015, DA1-016, DA1-016a	Construction, operation and maintenance of the authorised development
DA1-017	Access to land for the purpose of carrying out the authorised development including the power to carry out any ancillary works necessary to facilitate that access
DA1-018, DA1-019, DA1-019a, DA1-020, DA1-020a, DA1-021	Construction, operation and maintenance of the authorised development
DA1-022	Access to land for the purpose of carrying out the authorised development including the power to carry out any ancillary works necessary to facilitate that access
DA1-023, DA1-024	Construction, operation and maintenance of the authorised development
DA1-025, DA1-026	Access to land for the purpose of carrying out the authorised development including the power to carry out any ancillary works necessary to facilitate that access

DA1-027, DA1-028	Construction, operation and maintenance of the authorised development
DA1-029	Access to land for the purpose of carrying out the authorised development including the power to carry out any ancillary works necessary to facilitate that access
DA1-030	Construction, operation and maintenance of the authorised development
DA1-031	Access to land for the purpose of carrying out the authorised development including the power to carry out any ancillary works necessary to facilitate that access
DA1-032, DA1-033, DA1-034	Construction, operation and maintenance of the authorised development
DA1-035	Access to land for the purpose of carrying out the authorised development including the power to carry out any ancillary works necessary to facilitate that access
DA1-036, DA1-037, DA1-038, DA1-039, DA1-040, DA1-041, DA1-042, DA1-043, DA1-044, DA1-045, DA1-046, DA1-047	Construction, operation and maintenance of the authorised development
DA1-048	Access to land for the purpose of carrying out the authorised development including the power to carry out any ancillary works necessary to facilitate that access
DA1-049, DA1-050, DA1-051	Construction, operation and maintenance of the authorised development
DA1-052	Access to land for the purpose of carrying out the authorised development including the power to carry out any ancillary works necessary to facilitate that access
DA1-053, DA1-054, DA1-055, DA1-056, DA1-057, DA1-058	Construction, operation and maintenance of the authorised development
DA1-059	Access to land for the purpose of carrying out the authorised development including the power to carry out any ancillary works necessary to facilitate that access
DA1-060	Construction, operation and

	maintenance of the authorised development
DA1-061	Access to land for the purpose of carrying out the authorised development including the power to carry out any ancillary works necessary to facilitate that access
DA1-062	Construction, operation and maintenance of the authorised development
DA1-063, DA2-001, DA2-002	Access to land for the purpose of carrying out the authorised development including the power to carry out any ancillary works necessary to facilitate that access
DA2-003	Construction, operation and maintenance of the authorised development
DA2-004	Access to land for the purpose of carrying out the authorised development including the power to carry out any ancillary works necessary to facilitate that access
DA2-005	Construction, operation and maintenance of the authorised development
DA2-006	Access to land for the purpose of carrying out the authorised development including the power to carry out any ancillary works necessary to facilitate that access
DA2-007, DA2-008, DA2-009	Construction, operation and maintenance of the authorised development
DA2-010	Access to land for the purpose of carrying out the authorised development including the power to carry out any ancillary works necessary to facilitate that access
DA2-011	Construction, operation and maintenance of the authorised development
DA2-012	Access to land for the purpose of carrying out the authorised development including the power to carry out any ancillary works necessary to facilitate that access
DA2-013	Construction, operation and maintenance of the authorised

	development
DA2-014	Access to land for the purpose of carrying out the authorised development including the power to carry out any ancillary works necessary to facilitate that access
DA2-015, DA2-016, DA2-017, DA2-017a, DA2-019	Construction, operation and maintenance of the authorised development
DA2-020	Access to land for the purpose of carrying out the authorised development including the power to carry out any ancillary works necessary to facilitate that access
DA2-022, DA2-025	Construction, operation and maintenance of the authorised development
DA2-027	Access to land for the purpose of carrying out the authorised development including the power to carry out any ancillary works necessary to facilitate that access
DA2-028	Construction, operation and maintenance of the authorised development
DA2-030, DA2-031	Access to land for the purpose of carrying out the authorised development including the power to carry out any ancillary works necessary to facilitate that access
DA2-032, DA2-033, DA2-035, DA2-036	Construction, operation and maintenance of the authorised development
DA3-001	Access to land for the purpose of carrying out the authorised development including the power to carry out any ancillary works necessary to facilitate that access
DA3-003, DA3-004, DA3-005, DA3-006, DA3-007, DA3-008, DA3-009, DA3-010, DA3-011, DA3-012, DA3-013	Construction, operation and maintenance of the authorised development
DA3-014	Access to land for the purpose of carrying out the authorised development including the power to carry out any ancillary works necessary to facilitate that access
DA3-015, DA3-016	Construction, operation and maintenance of the authorised development

DA3-017, DA3-018, DA3-019, DA3-020, DA3-021	Access to land for the purpose of carrying out the authorised development including the power to carry out any ancillary works necessary to facilitate that access
DA3-022, DA3-024, DA3-025	Construction, operation and maintenance of the authorised development
DA3-026	Access to land for the purpose of carrying out the authorised development including the power to carry out any ancillary works necessary to facilitate that access
DA3-027, DA3-028, DA3-029, DA3-030	Construction, operation and maintenance of the authorised development
DA3-031, DA3-032	Access to land for the purpose of carrying out the authorised development including the power to carry out any ancillary works necessary to facilitate that access
DA4-001	Construction, operation and maintenance of the authorised development
DA4-002, DA4-003, DA4-004	Access to land for the purpose of carrying out the authorised development including the power to carry out any ancillary works necessary to facilitate that access
DA4-005	Construction, operation and maintenance of the authorised development
DA4-006	Access to land for the purpose of carrying out the authorised development including the power to carry out any ancillary works necessary to facilitate that access
DA4-007, DA4-008, DA4-009, DA4-010, DA4-011, DA4-012, DA4-013	Construction, operation and maintenance of the authorised development
DA4-014	Access to land for the purpose of carrying out the authorised development including the power to carry out any ancillary works necessary to facilitate that access
DA4-015	Construction, operation and maintenance of the authorised development
DA4-016	Access to land for the purpose of

	carrying out the authorised development including the power to carry out any ancillary works necessary to facilitate that access
DA4-017, DA4-018, DA4-019, DA4-020	Construction, operation and maintenance of the authorised development
DA4-021	Access to land for the purpose of carrying out the authorised development including the power to carry out any ancillary works necessary to facilitate that access
DA4-022, DA4-023	Construction, operation and maintenance of the authorised development
DA4-024	Access to land for the purpose of carrying out the authorised development including the power to carry out any ancillary works necessary to facilitate that access
DA4-025, DA4-026, DA4-027, DA4-027a, DA4-028, DA4-029, DA4-030, DA4-031, DA4-031a, DA4-031b, DA4-032, DA4-033, DA4-034, DA4-035, DA4-036, DA4-036a, DA4-036b, DA4-037, DA4-038, DA4-039	Construction, operation and maintenance of the authorised development
DA4-040, DA4-041	Access to land for the purpose of carrying out the authorised development including the power to carry out any ancillary works necessary to facilitate that access
DA4-042	Construction, operation and maintenance of the authorised development
DA4-043	Access to land for the purpose of carrying out the authorised development including the power to carry out any ancillary works necessary to facilitate that access
DA4-044, DA4-045	Construction, operation and maintenance of the authorised development
DA4-046	Access to land for the purpose of carrying out the authorised development including the power to carry out any ancillary works necessary to facilitate that access

DA4-047	Construction, operation and maintenance of the authorised development
DB1-001	Access to land for the purpose of carrying out the authorised development including the power to carry out any ancillary works necessary to facilitate that access
DB1-002	Construction, operation and maintenance of the authorised development
DB1-003, DB1-004	Access to land for the purpose of carrying out the authorised development including the power to carry out any ancillary works necessary to facilitate that access
DB1-005	Construction, operation and maintenance of the authorised development
DB1-006	Access to land for the purpose of carrying out the authorised development including the power to carry out any ancillary works necessary to facilitate that access
DB1-007	Construction, operation and maintenance of the authorised development
DB1-008	Access to land for the purpose of carrying out the authorised development including the power to carry out any ancillary works necessary to facilitate that access
DB1-009	Construction, operation and maintenance of the authorised development
DB1-010	Access to land for the purpose of carrying out the authorised development including the power to carry out any ancillary works necessary to facilitate that access
DB1-011, DB1-011a	Construction, operation and maintenance of the authorised development
DB1-012	Access to land for the purpose of carrying out the authorised development including the power to carry out any ancillary works necessary to facilitate that access
DB1-013, DB1-014, DB1-015, DB1-016	Construction, operation and

	maintenance of the authorised development
DB1-017	Access to land for the purpose of carrying out the authorised development including the power to carry out any ancillary works necessary to facilitate that access
DB1-018, DB1-019, DB1-019a, DB1-020	Construction, operation and maintenance of the authorised development
DB1-021	Access to land for the purpose of carrying out the authorised development including the power to carry out any ancillary works necessary to facilitate that access
DB1-022, DB1-023	Construction, operation and maintenance of the authorised development
DB1-024, DB1-025	Access to land for the purpose of carrying out the authorised development including the power to carry out any ancillary works necessary to facilitate that access
DB1-026, DB1-027	Construction, operation and maintenance of the authorised development
DB1-028	Access to land for the purpose of carrying out the authorised development including the power to carry out any ancillary works necessary to facilitate that access
DB1-029	Construction, operation and maintenance of the authorised development
DB1-030	Access to land for the purpose of carrying out the authorised development including the power to carry out any ancillary works necessary to facilitate that access
DB1-031, DB1-032	Construction, operation and maintenance of the authorised development
DB1-033	Access to land for the purpose of carrying out the authorised development including the power to carry out any ancillary works necessary to facilitate that access
DB1-034, DB1-035, DB1-036, DB1-037	Construction, operation and maintenance of the authorised

	development
DB1-038	Access to land for the purpose of carrying out the authorised development including the power to carry out any ancillary works necessary to facilitate that access
DB1-039, DB1-040, DB1-041, DB1-042, DB1-043	Construction, operation and maintenance of the authorised development
DB1-044	Access to land for the purpose of carrying out the authorised development including the power to carry out any ancillary works necessary to facilitate that access
DB1-045, DB1-046, DB1-047, DB1-048	Construction, operation and maintenance of the authorised development
DB1-049	Access to land for the purpose of carrying out the authorised development including the power to carry out any ancillary works necessary to facilitate that access
DB1-050, DB1-051, DB1-052, DB1-053, DB1-054	Construction, operation and maintenance of the authorised development
DB1-055	Access to land for the purpose of carrying out the authorised development including the power to carry out any ancillary works necessary to facilitate that access
DB1-056	Construction, operation and maintenance of the authorised development
DB1-057	Access to land for the purpose of carrying out the authorised development including the power to carry out any ancillary works necessary to facilitate that access
DB1-058	Construction, operation and maintenance of the authorised development
DB1-059, DB2-001, DB2-002	Access to land for the purpose of carrying out the authorised development including the power to carry out any ancillary works necessary to facilitate that access
DB2-003	Construction, operation and maintenance of the authorised development

DB2-004	Access to land for the purpose of carrying out the authorised development including the power to carry out any ancillary works necessary to facilitate that access
DB2-005	Construction, operation and maintenance of the authorised development
DB2-006	Access to land for the purpose of carrying out the authorised development including the power to carry out any ancillary works necessary to facilitate that access
DB2-007, DB2-008, DB2-009	Construction, operation and maintenance of the authorised development
DB2-010	Access to land for the purpose of carrying out the authorised development including the power to carry out any ancillary works necessary to facilitate that access
DB2-011	Construction, operation and maintenance of the authorised development
DB2-012	Access to land for the purpose of carrying out the authorised development including the power to carry out any ancillary works necessary to facilitate that access
DB2-013	Construction, operation and maintenance of the authorised development
DB2-014	Access to land for the purpose of carrying out the authorised development including the power to carry out any ancillary works necessary to facilitate that access
DB2-015, DB2-016, DB2-017, DB2-017a, DB2-019	Construction, operation and maintenance of the authorised development
DB2-020	Access to land for the purpose of carrying out the authorised development including the power to carry out any ancillary works necessary to facilitate that access
DB2-022, DB2-025	Construction, operation and maintenance of the authorised development
DB2-027	Access to land for the purpose of

	carrying out the authorised development including the power to carry out any ancillary works necessary to facilitate that access
DB2-028	Construction, operation and maintenance of the authorised development
DB2-030, DB2-031	Access to land for the purpose of carrying out the authorised development including the power to carry out any ancillary works necessary to facilitate that access
DB2-032, DB2-033, DB2-035, DB2-036	Construction, operation and maintenance of the authorised development
DB3-001	Access to land for the purpose of carrying out the authorised development including the power to carry out any ancillary works necessary to facilitate that access
DB3-003, DB3-004, DB3-005, DB3-006, DB3-007, DB3-008, DB3-009, DB3-010, DB3-011, DB3-012, DB3-013	Construction, operation and maintenance of the authorised development
DB3-014	Access to land for the purpose of carrying out the authorised development including the power to carry out any ancillary works necessary to facilitate that access
DB3-015, DB3-016	Construction, operation and maintenance of the authorised development
DB3-017, DB3-018, DB3-019, DB3-020, DB3-021	Access to land for the purpose of carrying out the authorised development including the power to carry out any ancillary works necessary to facilitate that access
DB3-022, DB3-024, DB3-025	Construction, operation and maintenance of the authorised development
DB3-026	Access to land for the purpose of carrying out the authorised development including the power to carry out any ancillary works necessary to facilitate that access
DB3-027, DB3-028, DB3-029, DB3-030	Construction, operation and maintenance of the authorised development
DB3-031, DB3-032	Access to land for the purpose of carrying out the authorised development

	including the power to carry out any ancillary works necessary to facilitate that access
DB4-001	Construction, operation and maintenance of the authorised development
DB4-002, DB4-003, DB4-004	Access to land for the purpose of carrying out the authorised development including the power to carry out any ancillary works necessary to facilitate that access
DB4-005	Construction, operation and maintenance of the authorised development
DB4-006	Access to land for the purpose of carrying out the authorised development including the power to carry out any ancillary works necessary to facilitate that access
DB4-007, DB4-008, DB4-009, DB4-010, DB4-011, DB4-012, DB4-013	Construction, operation and maintenance of the authorised development
DB4-014	Access to land for the purpose of carrying out the authorised development including the power to carry out any ancillary works necessary to facilitate that access
DB4-015	Construction, operation and maintenance of the authorised development
DB4-016	Access to land for the purpose of carrying out the authorised development including the power to carry out any ancillary works necessary to facilitate that access
DB4-017, DB4-018, DB4-019, DB4-020	Construction, operation and maintenance of the authorised development
DB4-021	Access to land for the purpose of carrying out the authorised development including the power to carry out any ancillary works necessary to facilitate that access
DB4-022, DB4-023	Construction, operation and maintenance of the authorised development
DB4-024	Access to land for the purpose of carrying out the authorised development including the power to carry out any

	ancillary works necessary to facilitate that access
DB4-025, DB4-026, DB4-027, DB4-027a, DB4-028, DB4-029, DB4-030, DB4-031, DB4-031a, DB4-031b, DB4-032, DB4-033, DB4-034, DB4-035, DB4-036, DB4-036a, DB4-036b, DB4-037, DB4-038, DB4-039	Construction, operation and maintenance of the authorised development
DB4-040, DB4-041	Access to land for the purpose of carrying out the authorised development including the power to carry out any ancillary works necessary to facilitate that access
DB4-042	Construction, operation and maintenance of the authorised development
DB4-043	Access to land for the purpose of carrying out the authorised development including the power to carry out any ancillary works necessary to facilitate that access
DB4-044, DB4-045	Construction, operation and maintenance of the authorised development
DB4-046	Access to land for the purpose of carrying out the authorised development including the power to carry out any ancillary works necessary to facilitate that access
DB4-047	Construction, operation and maintenance of the authorised development
E1-001, E1-001a, E1-002, E1-003	Construction, operation and maintenance of the authorised development
E1-004	Access to land for the purpose of carrying out the authorised development including the power to carry out any ancillary works necessary to facilitate that access
E1-005, E1-006, E1-007, E1-008, E1-009, E1-010, E1-011, E1-012, E1-013, E1-014, E1-014a, E1-015	Construction, operation and maintenance of the authorised development
E1-016	Access to land for the purpose of carrying out the authorised development including the power to carry out any ancillary works necessary to facilitate that access

E1-017, E1-018, E1-019, E1-020, E1-021	Construction, operation and maintenance of the authorised development
E1-022, E1-023, E1-024	Access to land for the purpose of carrying out the authorised development including the power to carry out any ancillary works necessary to facilitate that access
E1-025, E1-026, E1-027	Construction, operation and maintenance of the authorised development
E1-028	Access to land for the purpose of carrying out the authorised development including the power to carry out any ancillary works necessary to facilitate that access
E1-029, E1-030	Construction, operation and maintenance of the authorised development
E1-031	Access to land for the purpose of carrying out the authorised development including the power to carry out any ancillary works necessary to facilitate that access
E1-032	Construction, operation and maintenance of the authorised development
E1-033	Access to land for the purpose of carrying out the authorised development including the power to carry out any ancillary works necessary to facilitate that access
E1-034, E1-035	Construction, operation and maintenance of the authorised development
E1-036	Access to land for the purpose of carrying out the authorised development including the power to carry out any ancillary works necessary to facilitate that access
E1-037, E1-038, E1-039, E1-040, E1-041, E2-001, E2-002, E2-003, E2-004, E2-005	Construction, operation and maintenance of the authorised development
E2-006	Access to land for the purpose of carrying out the authorised development including the power to carry out any ancillary works necessary to facilitate that access
E2-007, E2-008, E2-009, E2-010,	Construction, operation and

E2-011, E2-012, E2-013, E2-014, E2-015, E2-016, E2-017, E2-018, E2-019, E2-020, E2-021	maintenance of the authorised development
E2-022	Access to land for the purpose of carrying out the authorised development including the power to carry out any ancillary works necessary to facilitate that access
E2-023, E2-024, E2-025, E2-026	Construction, operation and maintenance of the authorised development
E2-027	Access to land for the purpose of carrying out the authorised development including the power to carry out any ancillary works necessary to facilitate that access
E2-028, E2-029, E2-030, E2-031, E2-032, E2-033, E2-034, E2-035	Construction, operation and maintenance of the authorised development
E2-036	Access to land for the purpose of carrying out the authorised development including the power to carry out any ancillary works necessary to facilitate that access
E2-037, E2-038, E2-039	Construction, operation and maintenance of the authorised development
E2-040	Access to land for the purpose of carrying out the authorised development including the power to carry out any ancillary works necessary to facilitate that access
E2-041	Construction, operation and maintenance of the authorised development
E2-042	Access to land for the purpose of carrying out the authorised development including the power to carry out any ancillary works necessary to facilitate that access
E2-043	Construction, operation and maintenance of the authorised development
E2-044	Access to land for the purpose of carrying out the authorised development including the power to carry out any ancillary works necessary to facilitate that access
E3-001	Construction, operation and

	maintenance of the authorised development
E3-002, E3-002a, E3-002b, E3-003, E3-004	Access to land for the purpose of carrying out the authorised development including the power to carry out any ancillary works necessary to facilitate that access
E3-005	Construction, operation and maintenance of the authorised development
E3-006, E3-007, E3-008, E3-009	Access to land for the purpose of carrying out the authorised development including the power to carry out any ancillary works necessary to facilitate that access
E3-010, E3-011	Construction, operation and maintenance of the authorised development
E3-012	Access to land for the purpose of carrying out the authorised development including the power to carry out any ancillary works necessary to facilitate that access
E3-013	Construction, operation and maintenance of the authorised development
E3-014, E3-016,	Access to land for the purpose of carrying out the authorised development including the power to carry out any ancillary works necessary to facilitate that access
E3-018	Construction, operation and maintenance of the authorised development
E3-019, E3-020, E3-022, E3-023	Access to land for the purpose of carrying out the authorised development including the power to carry out any ancillary works necessary to facilitate that access
E3-025	Construction, operation and maintenance of the authorised development
E3-026, E3-027, E3-028, E3-029, E3-030	Access to land for the purpose of carrying out the authorised development including the power to carry out any ancillary works necessary to facilitate that access
E3-031	Construction, operation and maintenance of the authorised

	development
E3-032, E3-033	Access to land for the purpose of carrying out the authorised development including the power to carry out any ancillary works necessary to facilitate that access
E3-034, E3-035, E3-036	Construction, operation and maintenance of the authorised development
E3-037	Access to land for the purpose of carrying out the authorised development including the power to carry out any ancillary works necessary to facilitate that access
E3-038, E3-039, E3-040, E3-041, E3-042, E3-043, E3-044, E3-045, E3-046, E3-047, E3-048, E3-049	Construction, operation and maintenance of the authorised development
E3-050, E3-051, E3-052	Access to land for the purpose of carrying out the authorised development including the power to carry out any ancillary works necessary to facilitate that access
E3-053	Construction, operation and maintenance of the authorised development
E3-054, E3-055, E3-056, E3-057	Access to land for the purpose of carrying out the authorised development including the power to carry out any ancillary works necessary to facilitate that access
E3-058	Construction, operation and maintenance of the authorised development
E3-059, E3-060, E3-061	Access to land for the purpose of carrying out the authorised development including the power to carry out any ancillary works necessary to facilitate that access
E3-062, E3-063, E3-064	Construction, operation and maintenance of the authorised development
E3-065	Access to land for the purpose of carrying out the authorised development including the power to carry out any ancillary works necessary to facilitate that access
E3-066	Construction, operation and maintenance of the authorised development

E3-067	Access to land for the purpose of carrying out the authorised development including the power to carry out any ancillary works necessary to facilitate that access
E3-068	Construction, operation and maintenance of the authorised development
E3-069, E3-070, E3-071	Access to land for the purpose of carrying out the authorised development including the power to carry out any ancillary works necessary to facilitate that access
E3-072, E3-073, E3-074	Construction, operation and maintenance of the authorised development
E3-075	Access to land for the purpose of carrying out the authorised development including the power to carry out any ancillary works necessary to facilitate that access
E3-076, E3-077, E3-078, E3-079, E3-080, E3-081, E3-082, E3-083	Construction, operation and maintenance of the authorised development
E3-084, E3-085	Access to land for the purpose of carrying out the authorised development including the power to carry out any ancillary works necessary to facilitate that access
E3-086, E3-087, E3-087a, E3-087b, E3-088, E3-088a, E3-088b, E3-089	Construction, operation and maintenance of the authorised development
E3-090	Access to land for the purpose of carrying out the authorised development including the power to carry out any ancillary works necessary to facilitate that access
E3-092, E3-094, E3-097, E3-098, E3-100, E3-102, E3-103, E3-103a, E3-103b, E3-105	Construction, operation and maintenance of the authorised development
E3-106	Access to land for the purpose of carrying out the authorised development including the power to carry out any ancillary works necessary to facilitate that access
E3-107	Construction, operation and maintenance of the authorised development
E3-108, E3-111	Access to land for the purpose of

	carrying out the authorised development including the power to carry out any ancillary works necessary to facilitate that access
E3-112, E3-113, E3-114, E3-115, E3-116	Construction, operation and maintenance of the authorised development
E3-117	Access to land for the purpose of carrying out the authorised development including the power to carry out any ancillary works necessary to facilitate that access
E3-118	Construction, operation and maintenance of the authorised development
E3-119	Access to land for the purpose of carrying out the authorised development including the power to carry out any ancillary works necessary to facilitate that access
E3-120	Construction, operation and maintenance of the authorised development
E3-123, E3-124	Access to land for the purpose of carrying out the authorised development including the power to carry out any ancillary works necessary to facilitate that access
E3-125, E3-126	Construction, operation and maintenance of the authorised development
E3-127, E3-130	Access to land for the purpose of carrying out the authorised development including the power to carry out any ancillary works necessary to facilitate that access
E3-131	Construction, operation and maintenance of the authorised development
E3-134	Access to land for the purpose of carrying out the authorised development including the power to carry out any ancillary works necessary to facilitate that access
E3-135, E3-136, E3-137, E3-139, E3-140	Construction, operation and maintenance of the authorised development
E4-001, E4-002, E4-003, E4-004, E4-005, E4-006, E4-007, E4-008,	Access to land for the purpose of carrying out the authorised development

E4-009, E4-010, E4-011, E4-016	including the power to carry out any ancillary works necessary to facilitate that access
E4-020, E4-021, E4-023, E4-024	Construction, operation and maintenance of the authorised development
E4-025	Access to land for the purpose of carrying out the authorised development including the power to carry out any ancillary works necessary to facilitate that access
E4-026, E4-028, E4-029	Construction, operation and maintenance of the authorised development
E4-032	Access to land for the purpose of carrying out the authorised development including the power to carry out any ancillary works necessary to facilitate that access
E4-033, E4-036, E4-037, E4-039, E4-040	Construction, operation and maintenance of the authorised development
E4-041	Access to land for the purpose of carrying out the authorised development including the power to carry out any ancillary works necessary to facilitate that access
E4-042	Construction, operation and maintenance of the authorised development
E4-043, E4-047, E4-049, E4-050, E4-051	Access to land for the purpose of carrying out the authorised development including the power to carry out any ancillary works necessary to facilitate that access
E4-054	Construction, operation and maintenance of the authorised development
E4-055, E4-056	Access to land for the purpose of carrying out the authorised development including the power to carry out any ancillary works necessary to facilitate that access
E4-057, E4-058	Construction, operation and maintenance of the authorised development
E4-059	Access to land for the purpose of carrying out the authorised development including the power to carry out any

	ancillary works necessary to facilitate that access
E4-060, E4-061	Construction, operation and maintenance of the authorised development
E4-062	Access to land for the purpose of carrying out the authorised development including the power to carry out any ancillary works necessary to facilitate that access
E4-063	Construction, operation and maintenance of the authorised development
E4-064, E4-065	Access to land for the purpose of carrying out the authorised development including the power to carry out any ancillary works necessary to facilitate that access
E4-066, E4-067, E4-068	Construction, operation and maintenance of the authorised development
E4-069	Access to land for the purpose of carrying out the authorised development including the power to carry out any ancillary works necessary to facilitate that access
E4-070, E4-071, E4-072, E4-073, E4-074, E4-075, F1-001, F1-002, F1-003, F1-004, F1-005, F1-007, F1-009, F1-012, F1-013, F1-014, F1-015	Construction, operation and maintenance of the authorised development
F1-016, F1-017, F1-018, F1-019, F1-020, F1-021, F1-022, F1-023	Access to land for the purpose of carrying out the authorised development including the power to carry out any ancillary works necessary to facilitate that access
F1-024, F1-025, F1-026, F1-028, F1-029, F1-030, F1-031, F1-034, F1-035, F1-038, F1-040, F1-041, F1-042, F1-043, F1-045, F1-046, F1-048	Construction, operation and maintenance of the authorised development
F1-050, F1-054	Access to land for the purpose of carrying out the authorised development including the power to carry out any ancillary works necessary to facilitate that access
F1-055, F1-056, F1-057, F1-058	Construction, operation and maintenance of the authorised development
F1-059, F1-060	Access to land for the purpose of carrying out the authorised development

	including the power to carry out any ancillary works necessary to facilitate that access
F1-061, F1-062	Construction, operation and maintenance of the authorised development
F1-063	Access to land for the purpose of carrying out the authorised development including the power to carry out any ancillary works necessary to facilitate that access
F1-064	Construction, operation and maintenance of the authorised development
F1-065	Access to land for the purpose of carrying out the authorised development including the power to carry out any ancillary works necessary to facilitate that access
F1-066	Construction, operation and maintenance of the authorised development
F1-069	Access to land for the purpose of carrying out the authorised development including the power to carry out any ancillary works necessary to facilitate that access
F1-070, F1-072, F1-074, F1-074a, F1-077	Construction, operation and maintenance of the authorised development
F1-078	Access to land for the purpose of carrying out the authorised development including the power to carry out any ancillary works necessary to facilitate that access
F1-080	Construction, operation and maintenance of the authorised development
F1-083, F1-086	Access to land for the purpose of carrying out the authorised development including the power to carry out any ancillary works necessary to facilitate that access
F1-087, F1-088, F1-089, F1-096	Construction, operation and maintenance of the authorised development
F1-105	Access to land for the purpose of carrying out the authorised development including the power to carry out any

	ancillary works necessary to facilitate that access
F1-106	Construction, operation and maintenance of the authorised development
F1-106a	Access to land for the purpose of carrying out the authorised development including the power to carry out any ancillary works necessary to facilitate that access
F1-116, F1-117, F1-119, F1-123, F1-124, F1-128, F1-130	Construction, operation and maintenance of the authorised development and Construction, operation and maintenance of the authorised development more than 9 metres beneath the surface
F1-133, F1-136, F1-141	Access to land for the purpose of carrying out the authorised development including the power to carry out any ancillary works necessary to facilitate that access
F1-143, F1-144, F1-145, F1-146	Access to land for the purpose of carrying out the authorised development including the power to carry out any ancillary works necessary to facilitate that access and Construction, operation and maintenance of the authorised development more than 9 metres beneath the surface
F1-149, F1-151, F1-152, F1-153, F1-156, F1-157, F1-159, F1-163, F1-164	Construction, operation and maintenance of the authorised development and Construction, operation and maintenance of the authorised development more than 9 metres beneath the surface
F1-165	Access to land for the purpose of carrying out the authorised development including the power to carry out any ancillary works necessary to facilitate that access and Construction, operation and maintenance of the authorised development more than 9 metres beneath the surface
F1-166, F2-001, F2-003	Construction, operation and maintenance of the authorised development and Construction, operation and maintenance of the authorised development more than 9

	metres beneath the surface
F2-004, F2-005	Access to land for the purpose of carrying out the authorised development including the power to carry out any ancillary works necessary to facilitate that access and Construction, operation and maintenance of the authorised development more than 9 metres beneath the surface
F2-006, F2-007, F2-008, F2-010, F2-011, F2-012, F2-013, F2-014, F2-015, F2-016, F2-017, F2-018, F2-019, F2-020, F2-021, F2-022, F2-023	Construction, operation and maintenance of the authorised development and Construction, operation and maintenance of the authorised development more than 9 metres beneath the surface
F2-024a, F2-026, F2-027, F2-028	Access to land for the purpose of carrying out the authorised development including the power to carry out any ancillary works necessary to facilitate that access and Construction, operation and maintenance of the authorised development more than 9 metres beneath the surface
F2-029, F2-030, F2-032, F2-033	Access to land for the purpose of carrying out the authorised development including the power to carry out any ancillary works necessary to facilitate that access
F3-025, F3-027, F3-027a	Construction, operation and maintenance of the authorised development and Construction, operation and maintenance of the authorised development more than 9 metres beneath the surface
F3-028	Access to land for the purpose of carrying out the authorised development including the power to carry out any ancillary works necessary to facilitate that access and Construction, operation and maintenance of the authorised development more than 9 metres beneath the surface
F3-029	Construction, operation and maintenance of the authorised development
F3-030	Access to land for the purpose of carrying out the authorised development

	including the power to carry out any ancillary works necessary to facilitate that access
F3-031	Construction, operation and maintenance of the authorised development
F3-032	Construction, operation and maintenance of the authorised development and Construction, operation and maintenance of the authorised development more than 9 metres beneath the surface
F3-034	Access to land for the purpose of carrying out the authorised development including the power to carry out any ancillary works necessary to facilitate that access
F3-035, F3-036	Construction, operation and maintenance of the authorised development
F3-037	Access to land for the purpose of carrying out the authorised development including the power to carry out any ancillary works necessary to facilitate that access
F3-038	Construction, operation and maintenance of the authorised development
F3-039	Access to land for the purpose of carrying out the authorised development including the power to carry out any ancillary works necessary to facilitate that access
F3-040	Construction, operation and maintenance of the authorised development
F3-043	Access to land for the purpose of carrying out the authorised development including the power to carry out any ancillary works necessary to facilitate that access
F3-044	Construction, operation and maintenance of the authorised development
F4-002	Access to land for the purpose of carrying out the authorised development including the power to carry out any ancillary works necessary to facilitate

	that access
F4-004	Access to land for the purpose of carrying out the authorised development including the power to carry out any ancillary works necessary to facilitate that access and Construction, operation and maintenance of the authorised development more than 9 metres beneath the surface
F4-005	Construction, operation and maintenance of the authorised development and Construction, operation and maintenance of the authorised development more than 9 metres beneath the surface
F4-009	Access to land for the purpose of carrying out the authorised development including the power to carry out any ancillary works necessary to facilitate that access
F4-011	Construction, operation and maintenance of the authorised development
F4-012, F4-013, F4-014	Access to land for the purpose of carrying out the authorised development including the power to carry out any ancillary works necessary to facilitate that access
F4-016	Construction, operation and maintenance of the authorised development
F4-017	Access to land for the purpose of carrying out the authorised development including the power to carry out any ancillary works necessary to facilitate that access
F4-018, F4-019, F4-021, F4-022, F4-023, F4-025, F4-026, F4-027, F4-030	Construction, operation and maintenance of the authorised development
F4-032	Access to land for the purpose of carrying out the authorised development including the power to carry out any ancillary works necessary to facilitate that access
F4-034, F4-035, F4-036, F4-038, F4-039, F4-040, F4-043, F4-045, F4-047, F4-048, F4-049, F4-050, F4-053, F4-054, F4-055, F4-056, F4-057, F4-058, F4-059, F4-060,	Construction, operation and maintenance of the authorised development

F4-061, F4-062, F4-063, F4-064, F4-065, F4-066, F4-067, F4-068, F4-069, F4-070, F4-071, F4-072, F4-073, F4-074, F4-075, F4-076, F4-077, F4-078, F4-079, F4-080, F4-081, F4-082, F4-083, F4-085, F4-086, F4-087, F4-088, F4-089, F4-090, F4-091, F4-094, F4-095, F4-096, F4-097, F4-098, F4-099, F4-100, F4-101, F4-103	
F4-105	Access to land for the purpose of carrying out the authorised development including the power to carry out any ancillary works necessary to facilitate that access
F4-107, F4-107a, F4-108, F4-109, F4-110, F4-111	Construction, operation and maintenance of the authorised development
F4-112	Access to land for the purpose of carrying out the authorised development including the power to carry out any ancillary works necessary to facilitate that access
F4-113, F4-114, F4-116, F4-118, F4-119, F4-123, F4-127, F4-137, F4-137a, F4-138, F4-139, F4-143, F4-145	Construction, operation and maintenance of the authorised development
F4-146	Access to land for the purpose of carrying out the authorised development including the power to carry out any ancillary works necessary to facilitate that access
F4-149	Construction, operation and maintenance of the authorised development
F4-150, F4-153, F4-154	Access to land for the purpose of carrying out the authorised development including the power to carry out any ancillary works necessary to facilitate that access
F5-001, F5-006, F5-016, F5-020, F5-023	Construction, operation and maintenance of the authorised development
F5-025	Access to land for the purpose of carrying out the authorised development including the power to carry out any ancillary works necessary to facilitate that access
F5-026, F5-037, F5-049, F5-050,	Construction, operation and

F5-051, F5-052, F5-054, F5-056, F5-057, F5-058, F5-059, F5-062	maintenance of the authorised development
F5-064	Access to land for the purpose of carrying out the authorised development including the power to carry out any ancillary works necessary to facilitate that access
F5-067, F5-069, F5-071	Construction, operation and maintenance of the authorised development
F5-073, F5-074, F5-075, F5-076, F5-078	Access to land for the purpose of carrying out the authorised development including the power to carry out any ancillary works necessary to facilitate that access

PART 2	
SP Manweb COMPULSORY ACQUISITION OF RIGHTS (classes 3 and 4)	
No. on Plan	Purpose for which land may be acquired
A1-008	Construction, operation and maintenance of the authorised development
A1-010, A1-011	Access to land for the purpose of carrying out the authorised development including the power to carry out any ancillary works necessary to facilitate that access
A1-022, A1-023, A1-027	Construction, operation and maintenance of the authorised development
A1-031	Access to land for the purpose of carrying out the authorised development including the power to carry out any ancillary works necessary to facilitate that access
A1-035	Construction, operation and maintenance of the authorised development
A1-038, A1-038a, A1-039, A1-045, A1-046, A1-048a, A1-052, A1-056a, A1-059	Access to land for the purpose of carrying out the authorised development including the power to carry out any ancillary works necessary to facilitate that access
A1-060, A1-061, A1-063	Construction, operation and

	maintenance of the authorised development
A1-064	Access to land for the purpose of carrying out the authorised development including the power to carry out any ancillary works necessary to facilitate that access
A1-065, A1-065a	Construction, operation and maintenance of the authorised development
A1-074	Access to land for the purpose of carrying out the authorised development including the power to carry out any ancillary works necessary to facilitate that access
A1-080, A2-024, A2-025, A2-026, A2-027, A2-028, A2-029, A2-030, A2-031, A2-032, A2-033, A2-034, A2-035, A2-036, A2-037, A2-038, A2-039, A2-040, A2-042, A2-043, A2-044, A2-045, A2-048, A2-049, A2-050, A2-051, A2-076, A2-079, A2-084, A2-085	Construction, operation and maintenance of the authorised development
A2-088, A2-089, A2-090, A2-091, A2-092, A2-093, A2-094	Access to land for the purpose of carrying out the authorised development including the power to carry out any ancillary works necessary to facilitate that access
A2-095, A2-097, A3-007, A3-016, A3-017, A3-018, A3-020, A3-021, A3-022, A3-023, A3-024, A3-025, A3-027, A3-029, A3-030, A3-031	Construction, operation and maintenance of the authorised development
A3-032, A3-038, A3-041, A3-046, A3-047	Access to land for the purpose of carrying out the authorised development including the power to carry out any ancillary works necessary to facilitate that access
A3-066, A3-067, A3-075, A4-009, A4-016, A4-020	Construction, operation and maintenance of the authorised development
A4-023, A4-028, A4-033, A4-040, A4-041, A4-043, A4-044	Access to land for the purpose of carrying out the authorised development including the power to carry out any ancillary works necessary to facilitate that access
A5-008, A5-009, A5-011, A5-012, A5-013, A5-017, A5-018, A5-019, A5-020	Construction, operation and maintenance of the authorised development
A5-022	Access to land for the purpose of

	carrying out the authorised development including the power to carry out any ancillary works necessary to facilitate that access
A5-023, A5-024	Construction, operation and maintenance of the authorised development
A5-027, A5-030, A5-034, A5-035	Access to land for the purpose of carrying out the authorised development including the power to carry out any ancillary works necessary to facilitate that access
A5-037	Construction, operation and maintenance of the authorised development
A5-039	Access to land for the purpose of carrying out the authorised development including the power to carry out any ancillary works necessary to facilitate that access
A5-040	Construction, operation and maintenance of the authorised development
A5-041	Access to land for the purpose of carrying out the authorised development including the power to carry out any ancillary works necessary to facilitate that access
A5-042, A5-045, A5-045a	Construction, operation and maintenance of the authorised development
A5-046	Access to land for the purpose of carrying out the authorised development including the power to carry out any ancillary works necessary to facilitate that access
B1-004, B1-005	Construction, operation and maintenance of the authorised development
B1-006	Access to land for the purpose of carrying out the authorised development including the power to carry out any ancillary works necessary to facilitate that access
B1-007, B1-008, B1-011	Construction, operation and maintenance of the authorised development
B1-012	Access to land for the purpose of carrying out the authorised development

	including the power to carry out any ancillary works necessary to facilitate that access
B1-013, B1-014, B1-015, B1-016	Construction, operation and maintenance of the authorised development
B1-017	Access to land for the purpose of carrying out the authorised development including the power to carry out any ancillary works necessary to facilitate that access
B1-018, B1-019, B1-021, B1-022	Construction, operation and maintenance of the authorised development
B1-023a	Access to land for the purpose of carrying out the authorised development including the power to carry out any ancillary works necessary to facilitate that access
B1-024, B1-026	Construction, operation and maintenance of the authorised development
B1-027	Access to land for the purpose of carrying out the authorised development including the power to carry out any ancillary works necessary to facilitate that access
B1-028, B1-029, B1-032, B1-034, B1-035, B1-036, B1-038, B1-039, B1-040	Construction, operation and maintenance of the authorised development
B1-041a	Access to land for the purpose of carrying out the authorised development including the power to carry out any ancillary works necessary to facilitate that access
B1-043, B1-047	Construction, operation and maintenance of the authorised development
B1-048a, B1-052, B1-053	Access to land for the purpose of carrying out the authorised development including the power to carry out any ancillary works necessary to facilitate that access
B1-055, B1-056, B1-058	Construction, operation and maintenance of the authorised development
B1-059	Access to land for the purpose of carrying out the authorised development including the power to carry out any

	ancillary works necessary to facilitate that access
B1-063	Construction, operation and maintenance of the authorised development
B1-067	Access to land for the purpose of carrying out the authorised development including the power to carry out any ancillary works necessary to facilitate that access
B1-068, B1-071, B1-072, B1-074, B1-076	Construction, operation and maintenance of the authorised development
B1-078, B1-081	Access to land for the purpose of carrying out the authorised development including the power to carry out any ancillary works necessary to facilitate that access
B1-083, B1-084	Construction, operation and maintenance of the authorised development
B1-085	Access to land for the purpose of carrying out the authorised development including the power to carry out any ancillary works necessary to facilitate that access
B1-087, B1-099, B1-100	Construction, operation and maintenance of the authorised development
B1-104	Access to land for the purpose of carrying out the authorised development including the power to carry out any ancillary works necessary to facilitate that access
B1-106, B1-107, B1-109, B1-110, B1-111, B1-113, B1-114, B1-115, B1-116, B1-117, B1-119, B1-120, B1-121, B1-122, B1-124, B1-125, B2-001	Construction, operation and maintenance of the authorised development
B2-004	Access to land for the purpose of carrying out the authorised development including the power to carry out any ancillary works necessary to facilitate that access
B2-006, B2-007, B2-009, B2-010, B2-011	Construction, operation and maintenance of the authorised development
B2-013	Access to land for the purpose of carrying out the authorised development

	including the power to carry out any ancillary works necessary to facilitate that access
B2-014, B2-015, B2-016, B2-018, B2-019, B2-020	Construction, operation and maintenance of the authorised development
B2-021	Access to land for the purpose of carrying out the authorised development including the power to carry out any ancillary works necessary to facilitate that access
B2-023, B2-024, B2-025, B2-026, B2-027	Construction, operation and maintenance of the authorised development
B2-036	Access to land for the purpose of carrying out the authorised development including the power to carry out any ancillary works necessary to facilitate that access
B2-041	Construction, operation and maintenance of the authorised development
B2-047	Access to land for the purpose of carrying out the authorised development including the power to carry out any ancillary works necessary to facilitate that access
B2-054	Construction, operation and maintenance of the authorised development
B2-055, B2-056	Access to land for the purpose of carrying out the authorised development including the power to carry out any ancillary works necessary to facilitate that access
B2-059, B2-063, B2-069, B2-073, B2-074	Construction, operation and maintenance of the authorised development
B2-077a, B2-081, B2-083, B2-084, B2-085	Access to land for the purpose of carrying out the authorised development including the power to carry out any ancillary works necessary to facilitate that access
B2-088, B2-091	Construction, operation and maintenance of the authorised development
B3-024	Access to land for the purpose of carrying out the authorised development including the power to carry out any

	ancillary works necessary to facilitate that access
B3-026, B3-027, B3-028, B3-029, B3-030	Construction, operation and maintenance of the authorised development
B3-031, B3-032	Access to land for the purpose of carrying out the authorised development including the power to carry out any ancillary works necessary to facilitate that access
B3-033, B3-034, B3-035, B3-036	Construction, operation and maintenance of the authorised development
B3-037	Access to land for the purpose of carrying out the authorised development including the power to carry out any ancillary works necessary to facilitate that access
B3-042, B3-046, B3-047	Construction, operation and maintenance of the authorised development
B3-048	Access to land for the purpose of carrying out the authorised development including the power to carry out any ancillary works necessary to facilitate that access
B3-050	Construction, operation and maintenance of the authorised development
B3-056, B3-064	Access to land for the purpose of carrying out the authorised development including the power to carry out any ancillary works necessary to facilitate that access
B3-065, B3-066, B3-067, B3-069, B3-071, B3-072, B3-073, B3-074	Construction, operation and maintenance of the authorised development
B3-076, B3-080	Access to land for the purpose of carrying out the authorised development including the power to carry out any ancillary works necessary to facilitate that access
B3-081, B3-083	Construction, operation and maintenance of the authorised development
B3-084, B3-090, B3-093, B3-094, B3-095, B3-101, B3-102, B3-109, B3-112	Access to land for the purpose of carrying out the authorised development including the power to carry out any ancillary works necessary to facilitate

	that access
B3-113, B3-114	Construction, operation and maintenance of the authorised development
B3-115	Access to land for the purpose of carrying out the authorised development including the power to carry out any ancillary works necessary to facilitate that access
B3-117	Construction, operation and maintenance of the authorised development
B3-118, B4-002	Access to land for the purpose of carrying out the authorised development including the power to carry out any ancillary works necessary to facilitate that access
B4-003, B4-004, B4-006, B4-008	Construction, operation and maintenance of the authorised development
B4-012	Access to land for the purpose of carrying out the authorised development including the power to carry out any ancillary works necessary to facilitate that access
B4-013	Construction, operation and maintenance of the authorised development
B4-014	Access to land for the purpose of carrying out the authorised development including the power to carry out any ancillary works necessary to facilitate that access
B4-015, B4-016, B4-028	Construction, operation and maintenance of the authorised development
B4-033, B4-038	Access to land for the purpose of carrying out the authorised development including the power to carry out any ancillary works necessary to facilitate that access
B4-040	Construction, operation and maintenance of the authorised development
B4-043	Access to land for the purpose of carrying out the authorised development including the power to carry out any ancillary works necessary to facilitate that access

B4-044, B4-048, B4-049, B4-051, B4-052, B4-054, B4-057	Construction, operation and maintenance of the authorised development
B4-058, B4-064, CA1-011, CA1-012	Access to land for the purpose of carrying out the authorised development including the power to carry out any ancillary works necessary to facilitate that access
CA1-013, CA1-014, CA1-015, CA1-016, CA1-018	Construction, operation and maintenance of the authorised development
CA1-019	Access to land for the purpose of carrying out the authorised development including the power to carry out any ancillary works necessary to facilitate that access
CA1-020	Construction, operation and maintenance of the authorised development
CA1-021, CA1-023	Access to land for the purpose of carrying out the authorised development including the power to carry out any ancillary works necessary to facilitate that access
CA1-025	Construction, operation and maintenance of the authorised development
CA1-031	Access to land for the purpose of carrying out the authorised development including the power to carry out any ancillary works necessary to facilitate that access
CA1-032	Construction, operation and maintenance of the authorised development
CA1-036	Access to land for the purpose of carrying out the authorised development including the power to carry out any ancillary works necessary to facilitate that access
CA1-037, CA1-038, CA1-039, CA1-041, CA1-042	Construction, operation and maintenance of the authorised development
CA1-043	Access to land for the purpose of carrying out the authorised development including the power to carry out any ancillary works necessary to facilitate that access
CA1-045	Construction, operation and

	maintenance of the authorised development
CA1-047, CA1-048, CA2-002	Access to land for the purpose of carrying out the authorised development including the power to carry out any ancillary works necessary to facilitate that access
CA2-003	Construction, operation and maintenance of the authorised development
CA2-006, CA2-007	Access to land for the purpose of carrying out the authorised development including the power to carry out any ancillary works necessary to facilitate that access
CA2-010, CA2-014, CA2-017	Construction, operation and maintenance of the authorised development
CA2-018, CA2-020, CA2-023	Access to land for the purpose of carrying out the authorised development including the power to carry out any ancillary works necessary to facilitate that access
CA2-032	Construction, operation and maintenance of the authorised development
CA2-034, CA2-035, CA2-049	Access to land for the purpose of carrying out the authorised development including the power to carry out any ancillary works necessary to facilitate that access
CA2-050, CA2-051, CA2-053, CA2-054	Construction, operation and maintenance of the authorised development
CA2-057	Access to land for the purpose of carrying out the authorised development including the power to carry out any ancillary works necessary to facilitate that access
CA2-060, CA2-063, CA2-064, CA2-065	Construction, operation and maintenance of the authorised development
CA2-066, CA2-067, CA2-070, CA2-072	Access to land for the purpose of carrying out the authorised development including the power to carry out any ancillary works necessary to facilitate that access
CA2-074	Construction, operation and maintenance of the authorised

	development
CA2-075, CA2-076, CA2-078, CA2-079	Access to land for the purpose of carrying out the authorised development including the power to carry out any ancillary works necessary to facilitate that access
CA2-080, CA2-081, CA2-082, CA2-083, CA2-084, CA2-085	Construction, operation and maintenance of the authorised development
CA2-087	Access to land for the purpose of carrying out the authorised development including the power to carry out any ancillary works necessary to facilitate that access
CA2-091	Construction, operation and maintenance of the authorised development
CA2-094, CA2-095, CA2-101a, CA2-103, CA2-104, CA2-108	Access to land for the purpose of carrying out the authorised development including the power to carry out any ancillary works necessary to facilitate that access
CA2-115	Construction, operation and maintenance of the authorised development
CA2-117, CA2-118, CA2-122, CA2-123	Access to land for the purpose of carrying out the authorised development including the power to carry out any ancillary works necessary to facilitate that access
CA2-124, CA2-126, CA2-131, CA2-132, CA3-001, CA3-002, CA3-004, CA3-006, CA3-007	Construction, operation and maintenance of the authorised development
CA3-008	Access to land for the purpose of carrying out the authorised development including the power to carry out any ancillary works necessary to facilitate that access
CA3-009	Construction, operation and maintenance of the authorised development
CA3-011, CA3-017	Access to land for the purpose of carrying out the authorised development including the power to carry out any ancillary works necessary to facilitate that access
CA3-020	Construction, operation and maintenance of the authorised development

CA3-023, CA3-024, CA3-025, CA3-026	Access to land for the purpose of carrying out the authorised development including the power to carry out any ancillary works necessary to facilitate that access
CA3-027, CA3-034, CA3-036, CA3-038, CA3-039, CA3-040, CA3-041	Construction, operation and maintenance of the authorised development
CA4-015	Access to land for the purpose of carrying out the authorised development including the power to carry out any ancillary works necessary to facilitate that access
CA4-020	Construction, operation and maintenance of the authorised development
CA4-021, CA4-024	Access to land for the purpose of carrying out the authorised development including the power to carry out any ancillary works necessary to facilitate that access
CA4-027, CA4-027a, CA4-027b	Construction, operation and maintenance of the authorised development
CA4-028, CA4-030, CA4-031, CA4-032, CA4-036, CA4-038	Access to land for the purpose of carrying out the authorised development including the power to carry out any ancillary works necessary to facilitate that access
CA4-041, CA4-048, CA4-049, CA4-050, CA4-051, CA4-055	Construction, operation and maintenance of the authorised development
CA4-057, CA4-058, CA5-001	Access to land for the purpose of carrying out the authorised development including the power to carry out any ancillary works necessary to facilitate that access
CA5-002a, CA5-003	Construction, operation and maintenance of the authorised development
CA5-004	Access to land for the purpose of carrying out the authorised development including the power to carry out any ancillary works necessary to facilitate that access
CA5-005	Construction, operation and maintenance of the authorised development
CA5-006	Access to land for the purpose of

	carrying out the authorised development including the power to carry out any ancillary works necessary to facilitate that access
CA5-009, CA5-010, CA5-012, CA5-013, CA5-015, CA5-015a, CA5-017	Construction, operation and maintenance of the authorised development
CA5-018, CA5-021, CA5-022	Access to land for the purpose of carrying out the authorised development including the power to carry out any ancillary works necessary to facilitate that access
CA5-025, CA5-026, CA5-027, CA7-028, CA7-030, CA7-033, CA7-036, CA7-037, CA7-039, CA7-040, CA7-042, CA7-042a, CA7-044, CA7-045	Construction, operation and maintenance of the authorised development
CA7-047, CA7-055, CA7-055a, CA7-056, CA7-065, CA7-069, CA7-073, CA7-075, CB1-011, CB1-012	Access to land for the purpose of carrying out the authorised development including the power to carry out any ancillary works necessary to facilitate that access
CB1-013, CB1-014, CB1-015, CB1-016, CB1-018	Construction, operation and maintenance of the authorised development
CB1-019	Access to land for the purpose of carrying out the authorised development including the power to carry out any ancillary works necessary to facilitate that access
CB1-020	Construction, operation and maintenance of the authorised development
CB1-021, CB1-023	Access to land for the purpose of carrying out the authorised development including the power to carry out any ancillary works necessary to facilitate that access
CB1-025	Construction, operation and maintenance of the authorised development
CB1-031	Access to land for the purpose of carrying out the authorised development including the power to carry out any ancillary works necessary to facilitate that access
CB1-032	Construction, operation and maintenance of the authorised development
CB1-036	Access to land for the purpose of

	carrying out the authorised development including the power to carry out any ancillary works necessary to facilitate that access
CB1-037, CB1-038, CB1-039, CB1-041, CB1-042	Construction, operation and maintenance of the authorised development
CB1-043	Access to land for the purpose of carrying out the authorised development including the power to carry out any ancillary works necessary to facilitate that access
CB1-045	Construction, operation and maintenance of the authorised development
CB1-047, CB1-048, CB2-002	Access to land for the purpose of carrying out the authorised development including the power to carry out any ancillary works necessary to facilitate that access
CB2-003	Construction, operation and maintenance of the authorised development
CB2-006, CB2-007	Access to land for the purpose of carrying out the authorised development including the power to carry out any ancillary works necessary to facilitate that access
CB2-010, CB2-014, CB2-017	Construction, operation and maintenance of the authorised development
CB2-018, CB2-020, CB2-023	Access to land for the purpose of carrying out the authorised development including the power to carry out any ancillary works necessary to facilitate that access
CB2-032	Construction, operation and maintenance of the authorised development
CB2-034, CB2-035, CB2-049	Access to land for the purpose of carrying out the authorised development including the power to carry out any ancillary works necessary to facilitate that access
CB2-050, CB2-051, CB2-053, CB2-054	Construction, operation and maintenance of the authorised development
CB2-057	Access to land for the purpose of carrying out the authorised development

	including the power to carry out any ancillary works necessary to facilitate that access
CB2-060, CB2-063, CB2-064, CB2-065	Construction, operation and maintenance of the authorised development
CB2-066, CB2-067, CB2-070, CB2-072	Access to land for the purpose of carrying out the authorised development including the power to carry out any ancillary works necessary to facilitate that access
CB2-074	Construction, operation and maintenance of the authorised development
CB2-075, CB2-076, CB2-078, CB2-079	Access to land for the purpose of carrying out the authorised development including the power to carry out any ancillary works necessary to facilitate that access
CB2-080, CB2-081, CB2-082, CB2-083, CB2-084, CB2-085	Construction, operation and maintenance of the authorised development
CB2-087	Access to land for the purpose of carrying out the authorised development including the power to carry out any ancillary works necessary to facilitate that access
CB2-091	Construction, operation and maintenance of the authorised development
CB2-094, CB2-095, CB2-101a, CB2-103, CB2-104, CB2-108	Access to land for the purpose of carrying out the authorised development including the power to carry out any ancillary works necessary to facilitate that access
CB2-115	Construction, operation and maintenance of the authorised development
CB2-117, CB2-118, CB2-122, CB2-123	Access to land for the purpose of carrying out the authorised development including the power to carry out any ancillary works necessary to facilitate that access
CB2-124, CB2-126, CB2-131, CB2-132, CB3-001, CB3-002, CB3-004, CB3-006, CB3-007	Construction, operation and maintenance of the authorised development
CB3-008	Access to land for the purpose of carrying out the authorised development including the power to carry out any

	ancillary works necessary to facilitate that access
CB3-009	Construction, operation and maintenance of the authorised development
CB3-011, CB3-017	Access to land for the purpose of carrying out the authorised development including the power to carry out any ancillary works necessary to facilitate that access
CB3-020	Construction, operation and maintenance of the authorised development
CB3-023, CB3-024, CB3-025, CB3-026	Access to land for the purpose of carrying out the authorised development including the power to carry out any ancillary works necessary to facilitate that access
CB3-027, CB3-034, CB3-036, CB3-038, CB3-039, CB3-040, CB3-041	Construction, operation and maintenance of the authorised development
CB4-015	Access to land for the purpose of carrying out the authorised development including the power to carry out any ancillary works necessary to facilitate that access
CB4-020	Construction, operation and maintenance of the authorised development
CB4-021, CB4-024	Access to land for the purpose of carrying out the authorised development including the power to carry out any ancillary works necessary to facilitate that access
CB4-026, CB4-026a, CB4-026b	Construction, operation and maintenance of the authorised development
CB4-027, CB4-029, CB4-031, CB4-035, CB4-037	Access to land for the purpose of carrying out the authorised development including the power to carry out any ancillary works necessary to facilitate that access
CB4-040, CB4-047, CB4-048, CB4-049, CB4-050, CB4-054	Construction, operation and maintenance of the authorised development
CB4-056, CB4-057, CB5-001	Access to land for the purpose of carrying out the authorised development including the power to carry out any ancillary works necessary to facilitate

	that access
CB5-002a, CB5-003	Construction, operation and maintenance of the authorised development
CB5-004	Access to land for the purpose of carrying out the authorised development including the power to carry out any ancillary works necessary to facilitate that access
CB5-005	Construction, operation and maintenance of the authorised development
CB5-006	Access to land for the purpose of carrying out the authorised development including the power to carry out any ancillary works necessary to facilitate that access
CB5-009, CB5-010, CB5-012, CB5-013, CB5-015, CB5-015a, CB5-017	Construction, operation and maintenance of the authorised development
CB5-018, CB5-021, CB5-022	Access to land for the purpose of carrying out the authorised development including the power to carry out any ancillary works necessary to facilitate that access
CB5-025, CB5-026, CB5-027, CB7-028, CB7-030, CB7-033, CB7-036, CB7-037, CB7-039, CB7-040, CB7-042, CB7-042a, CB7-044, CB7-045b	Construction, operation and maintenance of the authorised development
CB7-051, CB7-058, CB7-058a, CB7-060, CB7-064, CB7-068, CB7-070, DA1-006, DA1-007, DA1-008, DA1-010, DA1-012	Access to land for the purpose of carrying out the authorised development including the power to carry out any ancillary works necessary to facilitate that access
DA1-013, DA1-014, DA1-015, DA1-016, DA1-016a	Construction, operation and maintenance of the authorised development
DA1-017	Access to land for the purpose of carrying out the authorised development including the power to carry out any ancillary works necessary to facilitate that access
DA1-018, DA1-019, DA1-019a, DA1-020, DA1-020a, DA1-021	Construction, operation and maintenance of the authorised development
DA1-022, DA1-025, DA1-026, DA1-051, DA1-057, DA1-061, DA2-002, DA2-005, DA2-006, DA2-007, DA2-010	Access to land for the purpose of carrying out the authorised development including the power to carry out any ancillary works necessary to facilitate

	that access
DA2-011	Construction, operation and maintenance of the authorised development
DA2-012	Access to land for the purpose of carrying out the authorised development including the power to carry out any ancillary works necessary to facilitate that access
DA2-013	Construction, operation and maintenance of the authorised development
DA2-014, DA2-016, DB1-006, DB1-007, DB1-008, DB1-010, DB1-012	Access to land for the purpose of carrying out the authorised development including the power to carry out any ancillary works necessary to facilitate that access
DB1-013, DB1-014, DB1-015, DB1-016	Construction, operation and maintenance of the authorised development
DB1-017	Access to land for the purpose of carrying out the authorised development including the power to carry out any ancillary works necessary to facilitate that access
DB1-018, DB1-019, DB1-019a, DB1-020	Construction, operation and maintenance of the authorised development
DB1-021, DB1-024, DB1-025, DB1-047, DB1-053, DB1-057, DB2-002, DB2-005, DB2-006, DB2-007, DB2-010	Access to land for the purpose of carrying out the authorised development including the power to carry out any ancillary works necessary to facilitate that access
DB2-011	Construction, operation and maintenance of the authorised development
DB2-012	Access to land for the purpose of carrying out the authorised development including the power to carry out any ancillary works necessary to facilitate that access
DB2-013	Construction, operation and maintenance of the authorised development
DB2-016, E1-012, E1-014, E1-014a, E1-019	Access to land for the purpose of carrying out the authorised development including the power to carry out any ancillary works necessary to facilitate that access

E1-020	Construction, operation and maintenance of the authorised development
E1-022, E1-025, E1-027, E1-028	Access to land for the purpose of carrying out the authorised development including the power to carry out any ancillary works necessary to facilitate that access
E1-029, E2-024, E2-025, E2-026	Construction, operation and maintenance of the authorised development
E2-027	Access to land for the purpose of carrying out the authorised development including the power to carry out any ancillary works necessary to facilitate that access
E2-028	Construction, operation and maintenance of the authorised development
E2-030	Access to land for the purpose of carrying out the authorised development including the power to carry out any ancillary works necessary to facilitate that access
E2-033, E2-034, E2-035, E2-037	Construction, operation and maintenance of the authorised development
E3-016, E3-023, E3-026, E3-032, E3-035, E3-038	Access to land for the purpose of carrying out the authorised development including the power to carry out any ancillary works necessary to facilitate that access
E3-040, E3-041, E3-042, E3-043, E3-044, E3-045, E3-046, E3-047, E3-062, E3-064, E3-066	Construction, operation and maintenance of the authorised development
E3-070	Access to land for the purpose of carrying out the authorised development including the power to carry out any ancillary works necessary to facilitate that access
E3-074, E3-076, E3-077, E3-080	Construction, operation and maintenance of the authorised development
E3-087, E3-088	Access to land for the purpose of carrying out the authorised development including the power to carry out any ancillary works necessary to facilitate that access
E3-089, E3-092, E3-094, E3-097	Construction, operation and

	maintenance of the authorised development
E3-103	Access to land for the purpose of carrying out the authorised development including the power to carry out any ancillary works necessary to facilitate that access
E3-118, E3-125, E3-126	Construction, operation and maintenance of the authorised development
E3-130	Access to land for the purpose of carrying out the authorised development including the power to carry out any ancillary works necessary to facilitate that access
E3-131	Construction, operation and maintenance of the authorised development
E3-134	Access to land for the purpose of carrying out the authorised development including the power to carry out any ancillary works necessary to facilitate that access
E3-138	Construction, operation and maintenance of the authorised development
E3-139	Access to land for the purpose of carrying out the authorised development including the power to carry out any ancillary works necessary to facilitate that access
E3-140, E4-020, E4-022	Construction, operation and maintenance of the authorised development
E4-024, E4-025	Access to land for the purpose of carrying out the authorised development including the power to carry out any ancillary works necessary to facilitate that access
E4-027, E4-029, E4-030	Construction, operation and maintenance of the authorised development
E4-032	Access to land for the purpose of carrying out the authorised development including the power to carry out any ancillary works necessary to facilitate that access
E4-033, E4-036	Construction, operation and maintenance of the authorised

	development
E4-041	Access to land for the purpose of carrying out the authorised development including the power to carry out any ancillary works necessary to facilitate that access
E4-042	Construction, operation and maintenance of the authorised development
E4-047, E4-049, E4-051	Access to land for the purpose of carrying out the authorised development including the power to carry out any ancillary works necessary to facilitate that access
E4-054	Construction, operation and maintenance of the authorised development
E4-055, E4-056	Access to land for the purpose of carrying out the authorised development including the power to carry out any ancillary works necessary to facilitate that access
E4-057, E4-058	Construction, operation and maintenance of the authorised development
E4-059	Access to land for the purpose of carrying out the authorised development including the power to carry out any ancillary works necessary to facilitate that access
E4-060, E4-061	Construction, operation and maintenance of the authorised development
E4-062	Access to land for the purpose of carrying out the authorised development including the power to carry out any ancillary works necessary to facilitate that access
E4-063	Construction, operation and maintenance of the authorised development
E4-064, E4-065	Access to land for the purpose of carrying out the authorised development including the power to carry out any ancillary works necessary to facilitate that access
E4-066, E4-067, E4-068	Construction, operation and maintenance of the authorised development

E4-069	Access to land for the purpose of carrying out the authorised development including the power to carry out any ancillary works necessary to facilitate that access
E4-070, E4-071, E4-072, E4-073, E4-075, F1-024, F1-025, F1-026, F1-028, F1-029, F1-030, F1-031, F1-032, F1-034, F1-035, F1-038, F1-040, F1-041, F1-042, F1-043, F1-045, F1-046, F1-048, F1-055, F1-056, F1-057, F1-058, F1-061	Construction, operation and maintenance of the authorised development
F1-063, F1-065, F1-067, F1-069, F1-071	Access to land for the purpose of carrying out the authorised development including the power to carry out any ancillary works necessary to facilitate that access
F1-072	Construction, operation and maintenance of the authorised development
F1-073, F1-076, F1-077, F1-078, F1-079	Access to land for the purpose of carrying out the authorised development including the power to carry out any ancillary works necessary to facilitate that access
F1-080	Construction, operation and maintenance of the authorised development
F1-083, F1-084, F1-086	Access to land for the purpose of carrying out the authorised development including the power to carry out any ancillary works necessary to facilitate that access
F1-087, F1-088, F1-089, F1-093, F1-094	Construction, operation and maintenance of the authorised development
F1-095	Access to land for the purpose of carrying out the authorised development including the power to carry out any ancillary works necessary to facilitate that access
F1-096, F1-097	Construction, operation and maintenance of the authorised development
F1-098, F1-101, F1-105	Access to land for the purpose of carrying out the authorised development including the power to carry out any ancillary works necessary to facilitate that access

F1-106	Construction, operation and maintenance of the authorised development
F1-106a, F1-108, F1-112	Access to land for the purpose of carrying out the authorised development including the power to carry out any ancillary works necessary to facilitate that access
F1-149, F1-151, F1-159, F1-163	Construction, operation and maintenance of the authorised development
F2-005	Access to land for the purpose of carrying out the authorised development including the power to carry out any ancillary works necessary to facilitate that access
F2-008	Construction, operation and maintenance of the authorised development
F2-011	Access to land for the purpose of carrying out the authorised development including the power to carry out any ancillary works necessary to facilitate that access
F2-012	Construction, operation and maintenance of the authorised development
F2-016	Access to land for the purpose of carrying out the authorised development including the power to carry out any ancillary works necessary to facilitate that access
F2-017, F2-019	Construction, operation and maintenance of the authorised development
F4-009	Access to land for the purpose of carrying out the authorised development including the power to carry out any ancillary works necessary to facilitate that access
F4-011, F4-016	Construction, operation and maintenance of the authorised development
F4-017	Access to land for the purpose of carrying out the authorised development including the power to carry out any ancillary works necessary to facilitate that access
F4-018, F4-019, F4-021, F4-023,	Construction, operation and

F4-025, F4-027, F4-028, F4-034, F4-035, F4-036, F4-038, F4-039, F4-040, F4-043, F4-045, F4-047, F4-048, F4-050, F4-054, F4-055, F4-057, F4-059, F4-061, F4-064, F4-065, F4-066, F4-069, F4-071, F4-072, F4-075, F4-081, F4-082, F4-087, F4-088, F4-090, F4-091, F4-098, F4-099, F4-100, F4-101, F4-107, F4-107a, F4-108, F4-109, F4-110, F4-111, F4-114, F4-116, F4-118, F4-119, F4-123, F4-127, F4-137, F4-137a, F4-138, F4-139, F4-143, F4-145	maintenance of the authorised development
F4-146	Access to land for the purpose of carrying out the authorised development including the power to carry out any ancillary works necessary to facilitate that access
F4-149, F5-014, F5-015, F5-016, F5-020, F5-023, F5-024	Construction, operation and maintenance of the authorised development
F5-025	Access to land for the purpose of carrying out the authorised development including the power to carry out any ancillary works necessary to facilitate that access
F5-026, F5-037, F5-041, F5-047, F5-049, F5-050, F5-051, F5-052, F5-053, F5-054, F5-055, F5-056, F5-057, F5-058, F5-059, F5-061, F5-062, F5-067	Construction, operation and maintenance of the authorised development

6.3.2 Table 6.3 lists land where National Grid and SP Manweb (in relation to the SP Manweb Works) require temporary use of land. The specific purposes for which this land is to be used are stated in the table. The purpose of using this land is for the construction of the Authorised Development, including the provision of essential laydown areas at the main construction locations, to provide temporary access to work areas, to temporarily divert public footpaths away from work areas and for partial highway closures adjacent to work areas. National Grid (and SP Manweb (in relation to SP Manweb Works) may, by virtue of Article 26 and Article 27 use such land in advance of acquisition. This would allow land to be occupied without having to acquire it to carry out the works, then only acquiring a lesser area of land permanently, or a permanent right in the land (which must be specified in the Book of Reference), once works are completed. This would

have a lesser impact on the landowner and is thus a more proportionate approach.

- 6.3.3 Where National Grid or SP Manweb (in respect of the SP Manweb Works) require temporary use of land which is also subject to the powers of compulsory acquisition, prior to such land being acquired, such temporary use shall be only for the purpose for which the land or right may be acquired.

Table 6.3: Temporary Use of Land

**PART 1
NATIONAL GRID (classes 5 and 6)**

Isle of Anglesey County Council

(1) <i>Plot number of land shown on land plan</i>	(2) <i>Purpose for which temporary possession may be taken</i>	(3) <i>Relevant part of the Authorised Development</i>	(4) <i>Element of work in respect of land which is not required to be re-instated</i>
DA2-018	Construction of the authorised development and mitigation works	6	
DA2-021, DA2-023, DA2-024, DA2-026, DA2-029, DA2-034, DA3-002	Access to land for the purpose of carrying out the authorised development including the power to carry out any ancillary works necessary to facilitate that access	6, 6, 6, 6, 6	
DA3-023, DB2-018	Construction of the authorised development and mitigation works	6, 6	
DB2-021, DB2-023, DB2-024, DB2-026, DB2-029, DB2-034, DB3-002	Access to land for the purpose of carrying out the authorised development including the power to carry out any ancillary works necessary to	6, 6, 6, 6, 6	

	facilitate that access		
DB3-023, E3-093, E3-096, E3-099, E3-101, E3-110, E3-122, E3-128, E3-133, E4-015, E4-017, E4-018, E4-019, E4-031, E4-035, E4-045, E4-046, E4-048, E4-052, E4-053, F1-027	Construction of the authorised development and mitigation works	6, 7 & 8, 7 & 8, 7 & 8, 7 & 8, 7 & 8, 7 & 8, 7 & 8, 7 & 8, 7 & 8, 7 & 8, 7 & 8, 7 & 8, 7 & 8, 7 & 8, 7 & 8, 7 & 8, 7 & 8	
F1-033	Access to land for the purpose of carrying out the authorised development including the power to carry out any ancillary works necessary to facilitate that access	7 & 8	
F1-036	Construction of the authorised development and mitigation works	7 & 8	
F1-037	Access to land for the purpose of carrying out the authorised development including the power to carry out any ancillary works necessary to facilitate that access	7 & 8	
F1-039, F1-044, F1-047	Construction of the authorised development and mitigation works	7 & 8, 7 & 8, 7 & 8	
F1-049	Access to land for the purpose of carrying out the authorised development including the power to carry out any	7 & 8	

	ancillary works necessary to facilitate that access		
F1-053, F1-082, F1-091	Construction of the authorised development and mitigation works	7 & 8, 7 & 8, 7 & 8	
F1-099	Access to land for the purpose of carrying out the authorised development including the power to carry out any ancillary works necessary to facilitate that access	7 & 8	
F1-103, F1-109, F1-110, F1-121, F1-127, F1-129, F1-131, F1-132, F1-134, F1-135	Construction of the authorised development and mitigation works	7 & 8, 7 & 8, 7 & 8, 8, 8, 8, 8, 8, 8	
F1-142, F1-161	Construction of the authorised development and mitigation works and Construction, operation and maintenance of the authorised development more than 9 metres beneath the surface	8, 8	

Gwynedd County Council

<i>(1) Plot number of land shown on land plan</i>	<i>(2) Purpose for which temporary possession may be taken</i>	<i>(3) Relevant part of the Authorised Development</i>	<i>(4) Element of work in respect of land which is not required to be re-instated</i>
F3-042, F4-001	Construction of the authorised development and mitigation works	8, 8	
F4-008	Access to land for	8 & 9	

	the purpose of carrying out the authorised development including the power to carry out any ancillary works necessary to facilitate that access		
F4-010	Construction of the authorised development and mitigation works	8 & 9	
F4-015	Access to land for the purpose of carrying out the authorised development including the power to carry out any ancillary works necessary to facilitate that access	8 & 9	
F4-020, F4-024, F4-029	Construction of the authorised development and mitigation works	8 & 9, 8 & 9, 8 & 9	
F4-031	Access to land for the purpose of carrying out the authorised development including the power to carry out any ancillary works necessary to facilitate that access	8 & 9	
F4-033, F4-037	Construction of the authorised development and mitigation works	8 & 9, 8 & 9	
F4-041	Access to land for the purpose of carrying out the authorised development including the power	8 & 9	

	to carry out any ancillary works necessary to facilitate that access		
F4-042, F4-044, F4-046, F4-051, F4-052	Construction of the authorised development and mitigation works	8 & 9, 8 & 9, 8 & 9, 9, 9	
F4-084, F4-092	Access to land for the purpose of carrying out the authorised development including the power to carry out any ancillary works necessary to facilitate that access	8 & 9, 8 & 9 & 10	
F4-093, F4-102, F4-104, F4-106, F4-115, F4-120, F4-121	Construction of the authorised development and mitigation works	8 & 9 & 10, 9, 9, 9, 9, 9, 9 & 10	
F4-122, F4-124, F4-125	Access to land for the purpose of carrying out the authorised development including the power to carry out any ancillary works necessary to facilitate that access	9, 8 & 9 & 10 & 11, 9	
F4-126	Construction of the authorised development and mitigation works	9	
F4-128	Access to land for the purpose of carrying out the authorised development including the power to carry out any ancillary works necessary to facilitate that access	9 & 10	

F4-129	Construction of the authorised development and mitigation works	9	
F4-130, F4-131, F4-132	Access to land for the purpose of carrying out the authorised development including the power to carry out any ancillary works necessary to facilitate that access	9, 8 & 9 & 10 & 11, 9	
F4-133, F4-134, F4-136	Construction of the authorised development and mitigation works	9, 9, 9 & 10	
F4-140	Access to land for the purpose of carrying out the authorised development including the power to carry out any ancillary works necessary to facilitate that access	8 & 9 & 10 & 11	
F4-142, F4-144, F4-151	Construction of the authorised development and mitigation works	8 & 9 & 10 & 11, 8 & 9 & 10 & 11, 9 & 10	
F4-152, F5-012, F5-017, F5-021, F5-022, F5-027	Access to land for the purpose of carrying out the authorised development including the power to carry out any ancillary works necessary to facilitate that access	8 & 9 & 10 & 11, 11, 8 & 9 & 10 & 11, 8 & 9 & 10 & 11, 8 & 9 & 10 & 11, 8 & 9 & 10 & 11	
F5-029, F5-031, F5-033, F5-034, F5-035, F5-036, F5-038, F5-039	Construction of the authorised development and mitigation works	8 & 9 & 10 & 11, 11, 11, 11, 11, 11, 11	

F5-040	Access to land for the purpose of carrying out the authorised development including the power to carry out any ancillary works necessary to facilitate that access	8 & 9 & 10 & 11	
F5-043, F5-045, F5-046, F5-048, F5-060	Construction of the authorised development and mitigation works	11, 11, 11 & 12, 11, 11 & 12	
F5-063, F5-065	Access to land for the purpose of carrying out the authorised development including the power to carry out any ancillary works necessary to facilitate that access	8 & 9 & 10 & 11 & 12, 8 & 9 & 10 & 11 & 12	
F5-070	Construction of the authorised development and mitigation works	8 & 9 & 10 & 11 & 12	

**PART 2
SP MANWEB**

Isle of Anglesey County Council

<i>(1) Plot number of land shown on land plan</i>	<i>(2) Purpose for which temporary possession may be taken</i>	<i>(3) Relevant part of the Authorised Development</i>	<i>(4) Element of work in respect of land which is not required to be re- instated</i>
B2-028, B2-029, B2-030, B2-032, B2-033, B2-035, B2-037, B2-039, B2-042, B2-043, B2-044	Construction of the authorised development and mitigation works	4, 4, 4, 4, 4, 4, 4, 4, 4, 4, 4	B2-028, B2-029, B2-030, B2-032, B2-033, B2-035, B2-037, B2-039, B2-042, B2-043, B2-044

Gwynedd County Council

<i>(1) Plot number of land shown on land plan</i>	<i>(2) Purpose for which temporary possession may be taken</i>	<i>(3) Relevant part of the Authorised Development</i>	<i>(4) Element of work in respect of land which is not required to be re- instated</i>
F4-056, F4-060, F4-070, F4-073, F4-074, F4-076, F4-077, F4-089, F4-096, F4-102, F4-104, F4-106, F4-115, F4-120, F4-121	Construction of the authorised development and mitigation works	9, 9, 9, 9, 9, 9, 9, 9, 9, 9, 9, 9, 9, 9, 9 & 10	F4-056, F4-060, F4-070, F4-073, F4-074, F4-076, F4-077, F4-089, F4-096, F4-102, F4-104, F4-106, F4-115, F4-120, F4-121
F4-122, F4-125	Access to land for the purpose of carrying out the authorised development including the power to carry out any ancillary works necessary to facilitate that access	9, 9	
F4-126	Construction of the authorised development and mitigation works	9	F4-126
F4-128	Access to land for the purpose of carrying out the authorised development including the power to carry out any ancillary works necessary to facilitate that access	9 & 10	
F4-129	Construction of the authorised development and mitigation works	9	F4-129
F4-130, F4-132	Access to land for the purpose of carrying out the authorised development including the power	9, 9	

	to carry out any ancillary works necessary to facilitate that access		
F4-133, F4-134, F4-136	Construction of the authorised development and mitigation works	9, 9, 9 & 10	F4-133, F4-134, F4-136

6.3.4 Table 6.4 below lists land where National Grid or SP Manweb (in respect of the SP Manweb Works) will be seeking to extinguish private rights and restrictive covenants relating to apparatus to be removed from land that will be subject to temporary possession. This is because once the apparatus is removed; National Grid or SP Manweb (in respect of the SP Manweb Works) no longer require rights of access and maintenance over such land. Where apparatus is to be removed (and no new apparatus is required, noting the often close proximity of the two lines 4AP and 4ZA) this will involve restoration of the land to the reasonable satisfaction of the landowner with pylon foundations being removed to a depth of 1.5 meters so as to facilitate normal agricultural activities in the future.

Table 6.4: extinguishment of private rights and restrictive covenants relating to apparatus to be removed from land that is subject to temporary possession.

Part 1
NATIONAL GRID

(1) AREA	(2) PLOT
Isle of Anglesey County Council	A1-005, B1-053, B1-054, B1-063, B1-070, B1-075, B1-076, B1-086, B1-089, B1-091, B1-093, B1-094, B1-095, B1-098, B1-103, B1-104, B1-105, B1-108, B2-012, B2-021, B2-032, B2-040, B2-052, B2-076, B2-086, B2-089, B2-090, B2-095, B2-098, B2-102, B4-021, CA1-035, CA1-036, CA1-040, CA1-043, CA1-046, CA2-004, CA2-013, CA2-017, CA2-019, CA2-027, CA2-032, CA2-049, CA2-052, CA2-054, CB1-035, CB1-036, CB1-040, CB1-043, CB1-046, CB2-004, CB2-013,

	CB2-017, CB2-019, CB2-027, CB2-032, CB2-049, CB2-052, CB2-054
Gwynedd County Council	

Part 2
SP Manweb

(1) AREA	(2) PLOT
Isle of Anglesey County Council	B2-028, B2-029, B2-030, B2-032, B2-033, B2-035, B2-037, B2-039, B2-042, B2-043, B2-044
Gwynedd County Council	F4-056, F4-060, F4-070, F4-073, F4-074, F4-076, F4-077, F4-089, F4-096, F4-102, F4-104, F4-106, F4-115, F4-120, F4-121, F4-126, F4-129, F4-133, F4-134, F4-136

7 Justification for Powers of Compulsory Acquisition

7.1 SECTION 122 OF THE ACT

7.1.1 Section 122 of the Act provides that a draft DCO that includes compulsory acquisition powers may be granted only if the conditions in sections 122(2) and 122(3) of the Act are met.

7.1.2 The first condition (s. 122(2)) requires one of three criteria to be met, as follows;

- the land is required for the development to which the development consent relates; or
- the land is required to facilitate or is incidental to that development; or
- the land is replacement land to be given in exchange under section 131 or 132 of the Act.

7.1.3 The second condition (s. 122(3)) is that there is a compelling case in the public interest for compulsory acquisition.

7.1.4 Paragraphs 12 and 13 of the DCLG Guidance on compulsory acquisition (September 2013 edition) also identify that for the second condition to be met the Secretary of State (SoS) will need to be persuaded that the public benefits that would be derived from the compulsory acquisition will outweigh the private loss that would be suffered by those whose land is to be acquired.

7.1.5 That Guidance sets out the following general matters which a promoter of the Proposed Development must be able to demonstrate to the satisfaction of the SoS so as to justify an order granting development consent:

- That all reasonable alternatives to compulsory acquisition (including modifications to the scheme) have been explored;
- That the proposed interest in the land is for a legitimate purpose and is necessary and proportionate;

- That it has a clear idea of how it intends to use the land which it is proposing to acquire;
- That there is a reasonable prospect of the requisite funds becoming available; and
- There is a justification for interfering with the human rights of those with an interest in the land affected.

7.1.6 The following paragraphs explain how the section 122 conditions are met in the case of the Proposed Development.

7.2 SECTION 122(2)

7.2.1 Condition 1: “The land and rights in the land are required for the development to which the consent relates, or, the land is required to facilitate or is incidental to that development”.

7.2.2 Chapter 5 within this Statement sets out the use to which the land and rights to be acquired will be put. This will be for the uses also set out in Chapter 6 within this Statement being the construction, operation and maintenance of the 400kV connection. The justification for acquiring permanent easements (as opposed to wayleaves) is set out in Paragraph 7.4.1 of this Chapter 7.

7.2.3 The Book of Reference (**Document 3.3**) and the Land Plans (**Document 4.2**) and the Works Plans (**Document 4.4**) show the land that falls within the Order limits and the works proposed on such land and the land and rights required, as well as how such land and rights will be used.

7.2.4 In each case the acquisition of land or rights is necessary to deliver the Proposed Development and are proportionate to the degree of interference with any private rights.

7.2.5 Land that is subject to powers for temporary use will be affected for a limited duration. The majority of land which is subject to powers of compulsory acquisition will experience only minor interference with the use of the land. For example, a significant proportion of the land over which permanent rights will be acquired is in agricultural use, and the rights will be mostly for the siting of individual pylons or routeing of overhead conductor wires. Hence the owners of such land will be able to continue to use the land for this purpose once construction is completed and should experience only limited interference over the lifetime of the Proposed Development.

7.2.6 In respect of special category land, this is addressed in Chapter 10 of this document.

7.3 SECTION 122(3)

7.3.1 Condition 2: *“There is a compelling case in the public interest for compulsory acquisition.”*

7.3.2 The Proposed Development would provide critical transmission capacity necessary for the safe and secure connection of the Wylfa Newydd Nuclear Power Station.

7.3.3 The Project Need Case (**Document 7.1**) states the need for the Authorised Development. The Planning Statement (**Document 7.14**) sets out the policy context for the Authorised Development.

7.3.4 Chapter 3 within this document describes the multi stage process that National Grid has followed in developing the Proposed Development. This involved an iterative process involving appropriate environmental appraisal, consultation, consideration of alternatives and engineering design which has resulted in a scheme which balances the relevant matters including National Grid’s duties and government guidance.

7.3.5 As set out in chapter 7 of this document, the land and rights required for the Authorised Development are necessary to facilitate the scheme and National Grid has sought to ensure that a proportionate approach has been taken in identifying the permanent and temporary rights that need to be acquired to achieve the delivery of the scheme.

7.3.6 There is therefore a compelling case that the compulsory acquisition of land and rights outweighs the interference with private rights. There is a relatively limited interference with private rights in most cases, and the public interest in delivering the scheme on time would not be likely to be met without the use of compulsory acquisition powers. As such it is in the public interest for the land and rights described in the Land Plans and Book of Reference and not already owned by National Grid to be compulsorily acquired.

7.4 ALTERNATIVES TO COMPULSORY ACQUISITION

7.4.1 In order to construct, operate and maintain the Authorised Development, land and rights in the ownership of parties other than National Grid would need to be acquired. The Book of Reference (**Document 3.3**) and the Land Plans (**Document 4.2**) show the land and rights in land that are required and for what purpose. Further information as to the proposed purposes can

be found in the Design Drawings (**Document 4.13**), the Planning Statement (**Document 7.14**) and the Construction Drawings within the Environmental Statement (**volume 5**). In each case the land and rights sought are necessary to deliver the Proposed Development and are proportionate to the degree of interference with the interests and rights of landowners.

- 7.4.2 National Grid will also seek to use powers for temporary use, where appropriate, rather than compulsory acquisition of land or rights as the temporary use of land is more proportionate where the permanent acquisition of land or rights is not required. As detailed above, the proposed approach is to construct the Proposed Development using temporary possession powers, and then exercise powers of compulsory acquisition only once the section of the Proposed Development has been completed.
- 7.4.3 The nature of any linear infrastructure project is such that routeing and design needs to be undertaken holistically, and not on a holding by holding basis, in order to arrive at an optimum end to end design proposal. The start and end points of the connection are fixed, and avoidance of mid-route holdings where voluntary land rights could not be secured would result in a sub-optimal route that conflicts with national planning policy and guidance and would give rise to greater adverse environmental and socio-economic effects.
- 7.4.4 National Grid will continue to seek all land and rights it needs by voluntary agreement. See section 8.2 (Seek to acquire).
- 7.4.5 This approach to making the application for the DCO in parallel to conducting negotiations to acquire land and rights in land by agreement is in accordance with paragraph 25 of the Guidance on compulsory acquisition issued by what was then DCLG.
- 7.4.6 In many cases rights currently exist for the undertaker to enter on and remove lines. These rights are contained in the existing wayleaves or easements. However in some cases less disturbance would result from taking an alternative access to that provided in the wayleave / easement and, therefore, compulsory acquisition of the necessary rights is sought within the draft DCO for the SP Manweb Works. The draft DCO also provides that National Grid (and SP Manweb) may temporarily occupy land in order to remove existing, and redundant, infrastructure.
- 7.4.7 Notwithstanding completing voluntary agreements, National Grid will seek powers of compulsory acquisition through the draft DCO as compulsory acquisition powers will enable National Grid to deliver its statutory and

contractual duties without potential delay, if for any reason the voluntary acquisition of land or rights is ultimately unsuccessful.

7.4.8 National Grid seeks compulsory powers to acquire land and rights in land under the draft DCO from all relevant landowners, notwithstanding that voluntary agreements for purchase of land and/or the grant of rights of way may have been entered into, for the following reasons:

- An option may be obtained by agreement prior to the DCO application or during the DCO application process, rather than the substantive right itself. The compulsory powers therefore provide a fall back should the voluntary agreements fail and cover all instances where the person with an interest in land is unwilling to grant the relevant land interest or right once the option has been exercised.
- Including all interests in the draft DCO allows all required land or rights to be obtained in the same way and through one process, potentially by General Vesting Declaration (GVD) or Notice to Treat / Notice of Entry. This is an effective way of compulsorily acquiring land and/or rights from multiple owners.
- Compulsory acquisition by GVD is effective against all interests in the land, so avoiding the risk of a failure to disclose a relevant interest or; an unknown interest.

7.4.9 Compulsory acquisition powers are also more readily enforceable, so reducing additional risk, cost and delay.

7.4.10 Paragraph 25 of the Guidance on compulsory acquisition confirms that for long, linear schemes, such as the Authorised Development:

“it may not be practical to acquire by agreement each plot of land. Where this is the case, it is reasonable to include provision authorising compulsory acquisition covering all the land required at the outset”

7.4.11 Without the powers of compulsory acquisition, the need for the Proposed Development could not be met, because of the risk that the land and rights required in the Order Land may not be assembled, leading to commensurate uncertainty as to the construction and associated programme. Where reliance has been placed on acquisition by private treaty, then the existence of the powers of compulsory acquisition would offer certainty that the necessary land and rights can be secured, should circumstances as highlighted above occur.

7.4.12 In defining the areas for permanent acquisition of land or rights within the Order Land, varying limits of deviation ('LoD') and parameters have been applied to the Works Plans and Design Drawings. LoD and parameters have been adopted to enable National Grid to ensure the deliverability of the Proposed Development. National Grid is seeking temporary rights over a wider area within the Order limits to provide a necessary and proportionate degree of flexibility as to the final alignment of the works. Once the exact location of the works has been determined then the extent of permanent acquisition can be minimised. The powers of temporary possession will extend across both the LoD and Order limits, and as detailed above these areas subject to temporary possession will be reduced down to reflect the finally constructed scheme, once the exact locations of the works have been determined.

7.5 ALTERNATIVES TO THE PROPOSED DEVELOPMENT

7.5.1 National Grid's multi-stage project development process is described in Chapter 3 within this document and a more detailed description of the change request process is in Chapter 5 of this document. At each stage of the process, National Grid considered alternative options balancing the environmental, economic, and engineering issues with the representations made during each stage of the consultation.

7.5.2 The assessment of alternatives at each stage is described in Chapter 2 of the ES (**Document 5.2**) and includes the consideration of alternative strategic options, route corridors, detailed routes, undergrounding and the consideration of representations made during consultation.

7.5.3 Having followed this multi-stage process, National Grid considers that the Proposed Development balances its duties and the feedback received during consultation.

7.6 THE PROPOSED INTEREST IN THE LAND IS LEGITIMATE, NECESSARY AND PROPORTIONATE

7.6.1 The need for the Proposed Development is set out in the Project Need Case (**Document 7.1**) and Strategic Options Report (**Document 7.2**) and is underpinned by NPS EN-1 and NPS EN-5. The compulsory acquisition of land and rights in land is necessary to deliver this connection.

7.6.2 Without the compulsory acquisition of the necessary interests in land, the delivery of the Proposed Development cannot be guaranteed. As contemplated by the Planning Act 2008 it is a proportionate use of compulsory acquisition powers to acquire land and rights in land for the Authorised Development.

7.6.3 Steps have been taken to ensure that the land and interests acquired are proportionate, including the following:

- The Strategic Options Report (**Document 7.2**) assessed alternative options (including offshore options) to deliver the necessary connection with more limited land take, but the acquisition of third party interests cannot be avoided to deliver the Authorised Development.
- The Order limits are drawn tightly to avoid any unnecessary interference with or extinguishments of third party rights.
- Where appropriate, National Grid has sought to take powers to temporarily use land, rather than permanent acquisition of land or rights.
- Wherever possible, National Grid is seeking rights in land rather than outright acquisition.

7.6.4 Compensation is payable for the compulsory acquisition of land or rights. Compensation is also payable for loss or damage caused by the exercise of any power of temporary use of land. Any dispute in respect of the compensation payable is to be determined by the Lands Chamber of the Upper Tribunal.

7.7 USE OF THE LAND TO BE ACQUIRED

7.7.1 National Grid has a clear idea of how it intends to use the land to be acquired and this is set out in detail in the Book of Reference (**Document 3.3**) and the Land Plans (**Document 4.2**) and is outlined in Chapter 6 within this Statement.

7.7.2 The land and rights to be acquired have been limited and will principally be used for the construction, operation, maintenance and dismantling of the 400 kV overhead line, as well as the tunnelled section of the connection (including THH and CSEC) and at the two substations, and therefore the powers of compulsory acquisition are necessary.

7.8 AVAILABILITY OF FUNDS FOR COMPENSATION

The Guidance in respect of compulsory acquisition indicates that an applicant should be able to demonstrate that there is a 'reasonable prospect' of the requisite funds becoming available. The Funding Statement (**Document 3.2**) which accompanies the application sets out how the Authorised Development would be funded and demonstrates that there is a reasonable prospect of the requisite funds being available both to pay any

compensation arising from the exercise of powers of compulsory acquisition and to construct the Proposed Development.

8 National Grid's Approach to Acquiring Land and Rights in Land by Agreement

8.1 STRATEGY

- 8.1.1 Since the announcement of the preferred route alignment and the start of the project-wide statutory consultation in October 2016, National Grid has engaged or endeavoured to engage with all owners and occupiers of the land required for or affected by the Proposed Development. The engagement forms part of the consultation process, to obtain feedback on the proposals and where appropriate, discussions have been held about the potential implications of the Proposed Development.
- 8.1.2 Voluntary rights in land for overhead lines and pylons will be sought by way of an option for easements under the terms of a Deed of Grant, as opposed to the grant of wayleaves.
- 8.1.3 For major infrastructure projects undertaken by National Grid, longevity and security of rights is essential in the context of National Grid's ability to create new and upgrade existing infrastructure networks and to support major power generation infrastructure projects. Therefore National Grid considers it essential to secure the grant of permanent easements rather than wayleaves whether by negotiation or through an application for a draft DCO for the following reasons:
- It is in the public interest to obtain the appropriate security for the electricity transmission network through the grant of permanent land rights and not temporary land rights.
 - Permanent and not temporary land rights are commensurate with the nature and lifetime of the infrastructure of the Proposed Development and to enable National Grid to comply with its statutory duty as the holder of the transmission licence in England and Wales.
- 8.1.4 In respect of the tunnel headhouses, freehold interests are being sought, due to the nature of the permanent works required. In respect of the tunnel

including under the Menai, a stratum of subsoil is being sought, either by way of freehold interest or freehold equivalent. In respect of Pentir substation extension, a freehold interest is being sought.

8.2 SEEK TO ACQUIRE

- 8.2.1 National Grid has sought to engage thoroughly with all potentially affected stakeholders, whether these stakeholders are individuals, organisations or statutory consultees.
- 8.2.2 National Grid has undertaken extensive consultation with all persons with an interest in the relevant land in order to try to avoid the need for the exercise of powers of compulsory acquisition. National Grid has offered terms for securing the rights and land needed through voluntary means.
- 8.2.3 Where appropriate for the overhead line, terms have been based upon National Grid's Land Rights Strategy. The general approach set out in the Land Rights Strategy has recently been reviewed and revised, and to increase the prospects of reaching voluntary agreement terms have been offered on the new and revised basis of the Land Rights Strategy.
- 8.2.4 Where the Proposed Development is for the siting of the substation extension or Tunnel Head House compounds it is National Grid's preference to acquire land voluntarily on a freehold basis.
- 8.2.5 Voluntary terms for the proposed tunnel have been based on a long leasehold. The order itself provides for freehold acquisition of subsoil stratum as a leasehold interest akin to that of freehold equivalent of the subsoil stratum is not available through compulsory acquisition. Appropriate market valuation of land value has generated a reasonable cost per linear metre.
- 8.2.6 For routeing purposes to optimise the scheme design, National Grid has sought to acquire three residential properties on a freehold basis by private treaty. Two acquisitions have been completed.
- 8.2.7 Whilst negotiations continue to voluntarily acquire a third property, the application contains two options at Talwrn. Option A does not include compulsory acquisition powers in respect of the freehold interest in the residential property (as National Grid would only use that if there is a private treaty agreement in place in respect of the freehold); and Option B goes around the property and would only require compulsory acquisition powers of oversail rights for conductors over agricultural land.

8.3 PROGRESS ON ACQUISITION

8.3.1 National Grid has acquired freehold property by private treaty agreement at:

- Cae Adda Fach, Llanfechell, Anglesey LL67 0DS
- Bryn Alaw, Rhosgoch, Anglesey LL66 0AB

8.3.2 Negotiations are continuing for both the acquisition of the two tunnel head house compound sites (to facilitate the undergrounding of the route under the Menai Strait) and a parcel of land for the extension of the Pentir substation.

8.3.3 Of the 125 landowners from whom permanent rights are sought for the overhead electric line, agreement has been reached with 93. Negotiations are ongoing with 32 landowners. National Grid is in the process of seeking the requisite interests or rights by way of private treaty

8.3.4 Negotiations are ongoing with 12 landowners from whom permanent interests are sought for the tunnel. National Grid is in the process of seeking the requisite interests or rights by way of private treaty

8.3.5 Several statutory undertakers, local authorities and major stakeholders who own land directly affected by the Proposed Development including those listed below. National Grid is in the process of seeking the requisite interests or rights by way of private treaty.

- Natural Resources Wales;
- Network Rail Infrastructure Limited;
- The Crown Estate;
- Isle of Anglesey Council;
- Gwynedd Council;
- Wales and West;
- Welsh Water;
- Openreach;
- CTIL;
- National Trust;

- The Welsh Ministers;
- The North & Mid Wales Trunk Road Agency;
- Scottish Power Manweb;
- Magnox;
- Nuclear Decommissioning Authority;
- Horizon Nuclear Power;
- Fibrespeed Limited;
- Zayo Group UK Limited;
- Airwave Solutions Limited;
- Arqiva Limited.

9 Related Applications, Orders, Consents

- 9.1.1 The draft DCO will be the principal consent required to allow the Proposed Development to proceed. In addition, there are other consents, licences and permissions that National Grid will require from other authorities, to allow certain elements of the development to proceed.
- 9.1.2 National Grid is in discussion with all relevant bodies and is not aware of anything that is likely to prevent the grant of these consents. The need for these consents does not therefore present any obstacle to the implementation of the Proposed Development.
- 9.1.3 These additional consents are listed in the Details of other Consents and Licences document, **(Document 7.15)**.

10 Special Category Land

- 10.1.1 The undertaker is seeking powers to compulsorily acquire rights over Special Category Land, more specifically classed as ‘public open space’ and ‘inalienable National Trust land’, which is shown on the Special Category Land Plans and Crown Land Plans (**Document 4.3**). The Book of Reference, (**Document 3.3**) also specifies the plots identified as Public Open Space and inalienable National Trust land, which are further detailed in table 10.1 below.
- 10.1.2 Sections 131 and 132 of the PA 2008 make provision for Special Parliamentary Procedure (SPP) to apply where a development consent order authorises the compulsory acquisition of land, or rights over land forming part of a common, open space or fuel field garden allotments, which is also documented in the Book of Reference.
- 10.1.3 SPP requires that powers of compulsory acquisition relating to the special category land be subject to further scrutiny by Parliament, before the development consent order covering the compulsory acquisition can come in to effect. A DCO is exempt from SPP where the Secretary of State is satisfied that one of the exceptions apply.
- 10.1.4 Section 131 PA2008 relates to the compulsory acquisition of “any land forming part of a common, open space or fuel or field garden”. The draft DCO proposes the compulsory acquisition of sub-soil strata where the surface above that strata is open space. Since sub-soil is not of itself open space, therefore Section 131 does not apply, and the SoS is not required to be satisfied that one of the exceptions in Section 131 apply.
- 10.1.5 Section 132 PA 2008 relates to the compulsory acquisition of rights over “any land forming part of a common, open space, or fuel or field garden”. The draft DCO proposes the compulsory acquisition of rights over open space. National Grid’s position is that the exception at Section 132(3) applies, namely that the Order Land when burdened with the order right will be “no less advantageous” than it was before. In relation to open space over which the conductors (the overhead wires strung between the pylons) are located, the public’s enjoyment of the open space will be no less advantageous; the conductors will be approximately 8.1 metres above ground allowing access to the open space as before. In relation to open

space on which pylons are located, the public's enjoyment of the open space will be no less advantageous; the pylons have an open lattice structure allowing access beneath and through the pylon. Access to the open space will therefore be as before.

- 10.1.6 The Order Land also includes inalienable National Trust Land. Section 130 PA 2008 confirms that if the National Trust object to the inclusion of their inalienable land within a draft DCO then unless that objection is withdrawn SPP applies. National Grid is in discussion with the National Trust in relation to an agreement to acquire the necessary interest in land. It is not anticipated that there will be any difficulty in securing this agreement.

Table 10.1 Special Category Land

Plot No.	Description of Land with extent stated in square meters	Category of land
CA3-016	35 square metres of wetland and public byway (Cors Erddreiniog Nature Reserve)	Open Space
CA3-022	137 square metres of wetland and public byway (Cors Erddreiniog Nature Reserve)	Open Space
CA3-028a	49 square metres of wetland and public byway (Cors Erddreiniog Nature Reserve)	Open Space
CA3-032a	14 square metres of woodland, wetland and public byway (Cors Erddreiniog Nature Reserve)	Open Space
CA3-043	603 square metres of Access track and verges (Cors Erddreiniog Nature Reserve)	Open Space
CA3-046	280 square metres of access track (Cors Erddreiniog Nature Reserve)	Open Space
CA3-047	216 square metres of verge (Cors Erddreiniog Nature Reserve)	Open Space
CA4-001	16 square metres of woodland and wetland (Cors Erddreiniog Nature Reserve)	Open Space
CA4-002	31 square metres of access track (Cors Erddreiniog Nature Reserve)	Open Space
CA4-003	52 square metres of verge (Cors Erddreiniog Nature Reserve)	Open Space
CA4-005	470 square metres of field, agricultural land, hedgerow and verge (Cors Erddreiniog Nature Reserve)	Open Space
CA4-007	4 square metres of hedgerow and verge (Cors Erddreiniog Nature Reserve)	Open Space
CA4-008	51 square metres of verge and access track (Cors Erddreiniog Nature Reserve)	Open Space
CA4-009	83 square metres of access track and verge (Cors Erddreiniog Nature Reserve)	Open Space

CB3-016	35 square metres of wetland and public byway (Cors Erddreiniog Nature Reserve)	Open Space
CB3-022	137 square metres of wetland and public byway (Cors Erddreiniog Nature Reserve)	Open Space
CB3-028a	49 square metres of wetland and public byway (Cors Erddreiniog Nature Reserve)	Open Space
CB3-032a	14 square metres of woodland, wetland and public byway (Cors Erddreiniog Nature Reserve)	Open Space
CB3-043	603 square metres of Access track and verges (Cors Erddreiniog Nature Reserve)	Open Space
CB3-046	280 square metres of access track (Cors Erddreiniog Nature Reserve)	Open Space
CB3-047	216 square metres of verge (Cors Erddreiniog Nature Reserve)	Open Space
CB4-001	16 square metres of woodland and wetland (Cors Erddreiniog Nature Reserve)	Open Space
CB4-002	31 square metres of access track (Cors Erddreiniog Nature Reserve)	Open Space
CB4-003	52 square metres of verge (Cors Erddreiniog Nature Reserve)	Open Space
CB4-005	470 square metres of field, agricultural land, hedgerow and verge (Cors Erddreiniog Nature Reserve)	Open Space
CB4-007	4 square metres of hedgerow and verge (Cors Erddreiniog Nature Reserve)	Open Space
CB4-008	51 square metres of verge and access track (Cors Erddreiniog Nature Reserve)	Open Space
CB4-009	83 square metres of access track and verge (Cors Erddreiniog Nature Reserve)	Open Space
DA4-027a	735 square metres of copse and dismantled railway (off unnamed road, Ceint)	Open Space
DA4-031	121 square metres of copse and dismantled railway (off unnamed road, Ceint)	Open Space
DA4-035	168 square metres of field, agricultural land and dismantled railway (off unnamed road, Ceint)	Open Space
DA4-036	404 square metres of copse and dismantled railway (off unnamed road, Ceint)	Open Space
DA4-036a	39 square metres of bridge carrying dismantled railway and river (Afon Ceint), bed and banks thereof (off unnamed road, Ceint)	Open Space
DA4-036b	85 square metres of field, agricultural land and dismantled railway (off unnamed road, Ceint)	Open Space
DA4-044	64 square metres of field, agricultural land and dismantled railway (off unnamed road, Ceint)	Open Space
DA4-046	153 square metres of field, agricultural land and dismantled railway (off unnamed road, Ceint)	Open Space
DA4-047	64 square metres of field, agricultural land and dismantled railway (off unnamed road, Ceint)	Open Space
DB4-027a	735 square metres of copse and dismantled railway	Open Space

	(off unnamed road, Ceint)	
DB4-031	121 square metres of copse and dismantled railway (off unnamed road, Ceint)	Open Space
DB4-035	168 square metres of field, agricultural land and dismantled railway (off unnamed road, Ceint)	Open Space
DB4-036	404 square metres of copse and dismantled railway (off unnamed road, Ceint)	Open Space
DB4-036a	39 square metres of bridge carrying dismantled railway and river (Afon Ceint), bed and banks thereof (off unnamed road, Ceint)	Open Space
DB4-036b	85 square metres of field, agricultural land and dismantled railway (off unnamed road, Ceint)	Open Space
DB4-044	64 square metres of field, agricultural land and dismantled railway (off unnamed road, Ceint)	Open Space
DB4-046	153 square metres of field, agricultural land and dismantled railway (off unnamed road, Ceint)	Open Space
DB4-047	64 square metres of field, agricultural land and dismantled railway (off unnamed road, Ceint)	Open Space
E3-002a	51 square metres of field, viewing area, verge and embankment (off A5152, Gaerwen)	Open Space
F1-138	4046 square metres of subsoil below woodland (off Brynsiencyn road, A4080, Plas Newydd)	National Trust land
F1-147	15822 square metres of subsoil below field, agricultural land and private access road (off Brynsiencyn road, A4080, Plas Newydd)	National Trust land
F1-148	32355 square metres of subsoil below woodland (off Brynsiencyn road, A4080, Plas Newydd)	National Trust land
F1-154	11282 square metres of subsoil below woodland (off Brynsiencyn road, A4080, Plas Newydd)	National Trust land
F1-158	2396 square metres of subsoil below foreshore (Menai Strait, Plas Newydd)	National Trust land
F1-160	2484 square metres of subsoil below field (off Brynsiencyn road, A4080, Plas Newydd)	National Trust land
F2-002	1 square metre of subsoil below field and woodland (off Brynsiencyn road, A4080, Plas Newydd)	National Trust land
F2-025	28444 square metres of subsoil below building and woodland (Druid cottage, Plas Newydd)	National Trust land
F2-031	45583 square metres of subsoil below private road and field (unnamed road, Plas Newydd)	National Trust land
F2-034	64016 square metres of subsoil below woodland, pond and watercourse (Plas Newydd, Llanddaniel Fab)	National Trust land
F2-035	29800 square metres of subsoil below foreshore (Menai Strait, Plas Newydd)	National Trust land
F2-036	1 square metre of subsoil below building (Druid Lodge, Plas Newydd)	National Trust land
F2-038	1459 square metres of subsoil below outbuilding, access track and recreational land (Conway Centre, Plas Newydd)	National Trust land

F2-039	52 square metres of subsoil below outbuilding, access track and recreational land (Conway Centre, Plas Newydd)	National Trust land
F2-041	44270 square metres of subsoil below foreshore (Menai Strait, Vaynol Park)	National Trust land
F2-043	418774 squares metres of subsoil below field, agricultural land, woodland, access track and pylon and overhead electricity lines (Vaynol Park, Capel Y Graig)	National Trust land
F2-049	246 square metres of subsoil below field and agricultural land (Vaynol Park, Capel Y Graig)	National Trust land
F3-003	9937 square metres of subsoil below field, agricultural land and woodland (Vaynol Park, Capel Y Graig)	National Trust land
F3-004	24580 square metres of subsoil below field, agricultural land and access track (Vaynol Park, Capel Y Graig)	National Trust land

11 Crown Land

- 11.1.1 The Proposed Development will also require the acquisition of subsoil strata of Crown Land and any interests over that Crown Land. Promoters cannot exercise compulsory purchase powers against The Crown. This leaves National Grid having to negotiate terms based on market value of the interest sought.
- 11.1.2 Part 4 of the Book of Reference (**Document 3.3**) identifies the plots within which the Crown has an interest and Table 11.1 below further details this information. Land identified as Crown Land is also shown on the Special Category Land Plans and Crown Land Plans (**Document 4.3**).
- 11.1.3 If a Crown interest is identified as a Category 1, 2 or 3 right and is therefore listed in Part(s) 1, 2 and/or 3 of the Book of Reference as appropriate, that Crown interest is also listed in Part 4 of the Book of Reference.
- 11.1.4 A Crown interest will arise from any Crown entity, which may not just be The Crown Estate, an example might be other government entities/departments.
- 11.1.5 Section 135(1) PA 2008 confirms that where an interest is held in land by or on behalf of The Crown that a draft DCO cannot include provision authorising its compulsory acquisition. It is therefore necessary in such cases to come to a voluntary agreement with The Crown.
- 11.1.6 National Grid is in discussions with The Crown Estate in relation to an agreement to acquire the necessary interests in land. It is not anticipated that there will be any difficulty in securing this agreement. The Crown Estate owns the sub-soil of the Menai Strait and an agreement is therefore required in order to construct and operate the tunnel section of the Proposed Development.

Table 11.1 plots that fall within Crown Land

Plot No	Description of Land with extent stated in square meters	Owners of any Crown Interest in the Land
E3-009	6004 square metres of public road, verges, public footpath (no 41/003/1) and pylon and	The Welsh Ministers

	overhead electricity lines (unnamed road, Star)	
E3-011	10258 square metres of public road, layby, verges and embankment (North Wales Expressway, A55, Star)	The Welsh Ministers
E3-012	1950 square metres of verge and overhead electricity lines (unnamed road, Star)	The Welsh Ministers
E3-013	1229 square metres of public road and verges (Ffordd Caergybi, A5, Star)	The Welsh Ministers
E4-001	341 square metres of public road and verges (unnamed road, Star)	The Welsh Ministers
E4-002	258 square metres of verge (unnamed road, Star)	The Welsh Ministers
E4-003	1918 square metres of public road and verge (unnamed road, Star)	The Welsh Ministers
E4-004	756 square metres of public road, verge and overhead electricity lines (unnamed road, Star)	The Welsh Ministers
E4-005	92 square metres of public road and verges (unnamed road, Star)	The Welsh Ministers
E4-006	239 square metres of public road and verges (unnamed road, Star)	The Welsh Ministers
E4-007	69 square metres of hardstanding (Ffordd Caergybi, A5, Star)	The Welsh Ministers
E4-008	5 square metres of hardstanding (Ffordd Caergybi, A5, Star)	The Welsh Ministers
E4-010	147 square metres of public road and hardstanding (Ffordd Caergybi, A5, Star)	The Welsh Ministers
E4-011	1140 square metres of public road, verge, footway and overhead electricity lines (Ffordd Caergybi, A5, Star)	The Welsh Ministers
F1-001	80 square metres of public road and verge (Ffordd Caergybi, A5, Star)	The Welsh Ministers
F1-002	367 square metres of public road, verge, slip road and overhead electricity lines (Ffordd	The Welsh Ministers

	Caergybi, A5, Llanfair Pwllgwyngyll)	
F1-003	989 square metres of public road and verges (Ffordd Caergybi, A5, Star)	The Welsh Ministers
F1-004	2 square metres of public road (Ffordd Caergybi, A5, Star)	The Welsh Ministers
F1-005	25 square metres of public road and verge (Ffordd Caergybi, A5, Star)	The Welsh Ministers
F1-006	2 square metres of verge (Ffordd Caergybi, A5, Star)	The Welsh Ministers
F1-007	1553 square metres of public road, verges and overhead electricity lines (Ffordd Caergybi, A5, Star)	The Welsh Ministers
F1-008	113 square metres of verge (Ffordd Caergybi, A5, Star)	The Welsh Ministers
F1-009	2015 square metres of verge, hedgerow, cycle lane, footway and overhead electricity lines (Ffordd Caergybi, A5, Star)	The Welsh Ministers
F1-010	92 square metres of verge, hedgerow and footway (Ffordd Caergybi, A5, Star)	The Welsh Ministers
F1-011	96 square metres of verge, hedgerow and footway (Ffordd Caergybi, A5, Star)	The Welsh Ministers
F1-012	149 square metres of field and agricultural land (off Ffordd Caergybi, A5, Star)	The Welsh Ministers
F1-013	185 square metres of verge and hedgerow (unnamed road, Llanfair Pwllgwyngyll)	The Welsh Ministers
F1-014	289 square metres of public road and verges (unnamed road, Llanfair Pwllgwyngyll)	The Welsh Ministers
F1-019	1 square metre of field and agricultural land (off unnamed road, Llanfair Pwllgwyngyll)	The Welsh Ministers
F1-020	1 square metre of field and agricultural land (off unnamed road, Llanfair Pwllgwyngyll)	The Welsh Ministers
F1-023	507 square metres of hedgerow and access stairs (off unnamed road, Llanfair Pwllgwyngyll)	The Welsh Ministers

F1-025	218 square metres of hedgerow (off unnamed road, Llanfair Pwllgwyngyll)	The Welsh Ministers
F1-027	6338 square metres of field and agricultural land (off unnamed road, Llanfair Pwllgwyngyll)	The Welsh Ministers
F1-028	989 square metres of field, agricultural land and overhead electricity lines (off unnamed road, Llanfair Pwllgwyngyll)	The Welsh Ministers
F1-030	104 square metres of field, agricultural land and overhead electricity lines (off unnamed road, Llanfair Pwllgwyngyll)	The Welsh Ministers
F1-033	5782 square metres of field, agricultural land and hedgerow (off unnamed road, Llanfair Pwllgwyngyll)	The Welsh Ministers
F1-034	888 square metres of field and agricultural land (off unnamed road, Llanfair Pwllgwyngyll)	The Welsh Ministers
F1-038	13 square metres of field and agricultural land (off unnamed road, Llanfair Pwllgwyngyll)	The Welsh Ministers
F1-039	5468 square metres of field, agricultural land and hedgerow (off unnamed road, Llanfair Pwllgwyngyll)	The Welsh Ministers
F1-041	1360 square metres of field, agricultural land and overhead electricity lines (off unnamed road, Llanfair Pwllgwyngyll)	The Welsh Ministers
F1-042	12 square metres of field and agricultural land (off unnamed road, Llanfair Pwllgwyngyll)	The Welsh Ministers
F1-158	2396 square metres of subsoil below foreshore (Menai Strait, Plas Newydd)	The Queen's Most Excellent Majesty In Right Of Her Crown
F1-162	1206 square metres of subsoil below Menai Strait and bed thereof	The Queen's Most Excellent Majesty In Right Of Her Crown
F2-035	29800 square metres of subsoil below foreshore (Menai Strait, Plas Newydd)	The Queen's Most Excellent Majesty In Right Of Her Crown

F2-037	298484 square metres of subsoil below Menai Strait and bed thereof	The Queen's Most Excellent Majesty In Right Of Her Crown
F2-041	44270 square metres of subsoil below foreshore (Menai Strait, Vaynol Park)	The Queen's Most Excellent Majesty In Right Of Her Crown
F3-006	112 square metres of subsoil below public road and verges (A487, Capel Y Graig)	The Welsh Ministers
F3-008	10019 square metres of subsoil below public road, verges, roundabout and footway (B4547, Capel Y Graig)	The Welsh Ministers
F3-010	3860 square metres of subsoil below public road, verges and roundabout (Y Felinheli Bypass, Capel Y Graig)	The Welsh Ministers
F3-015	5345 square metres of subsoil below public road, verges and woodland (Y Felinheli Bypass, A487, Capel Y Graig)	The Welsh Ministers
F3-016	4136 square metres of subsoil below public road, verges and woodland (Y Felinheli Bypass, A487, Capel Y Graig)	The Welsh Ministers
F3-018	788 square metres of subsoil below woodland (off A487, Capel Y Graig)	The Welsh Ministers
F3-040	2307 square metres of public road, verges, pylon and overhead electricity lines and telecommunication mast and apparatus (Ffordd Fodolydd, Pentir)	The Welsh Ministers
F3-044	278 square metres of public road and verges (Ffordd Fodolydd, Pentir)	The Welsh Ministers

12 Justification for Interference with Human Rights

12.1 THE HUMAN RIGHTS ACT : RELEVANT CONVENTION RIGHTS

- 12.1.1 The European Convention on Human Rights (the convention) was applied within UK domestic law by the Human Rights Act 1998 (the HRA).
- 12.1.2 The articles of the Convention that are relevant when determining whether a DCO should be made which includes powers of compulsory acquisition are Article 1 of the First Protocol to the Convention, Article 6 and Article 8.
- 12.1.3 The SoS must be persuaded that the purposes for which an order authorises the compulsory acquisition of land, are sufficient to justify interfering with the human rights of those with an interest in the land.
- 12.1.4 Article 1 of the First Protocol to the Convention protects the right of everyone to the peaceful enjoyment of possessions. No one can be deprived of possessions except in the public interest and subject to the conditions provided by relevant national and international laws. Any interference with possessions must be proportionate and in determining whether a particular measure is proportionate a fair balance should be struck between the demands of the general interest and the protection of the individual's rights.
- 12.1.5 Article 6 entitles those affected by powers sought for the Proposed Development to a fair and public hearing by an independent and impartial tribunal. These requirements would be secured by the availability of judicial review if the decision-making is not considered to be independent within the meaning of Article 6.
- 12.1.6 Article 8 protects the right of the individual to respect for his private and family life, his home and his correspondence. No public authority may interfere with this interest except if it is in accordance with the law and is necessary in the interests of, inter alia, national security, public safety or the economic well-being of the country. As with Article 1 of the First Protocol to the Convention, any interference if justified, must be proportionate.

12.1.7 The Authorised Development has the potential to infringe the human rights of persons who own property within the Order Land. Such infringement is authorised by law provided that:-

- The statutory procedures for making the DCO are followed and there is a compelling case in the public interest for the inclusion of powers of compulsory acquisition in the DCO; and
- Any interference with any Convention right is proportionate to the aim served.

12.2 COMPLIANCE WITH THE CONVENTION AND THE HUMAN RIGHTS ACT

12.2.1 National Grid is satisfied that, although Convention rights are likely to be engaged, the Authorised Development will not conflict with Convention rights and will be proportionate in that there is a compelling case in the public interest for the Authorised Development which outweighs the impact on individual rights. In this context, it is relevant that those affected will be entitled to compensation.

12.2.2 With regard to Article 1, First Protocol and Article 8, National Grid has weighed any interference with these Convention rights as a result of including compulsory powers within the DCO with the potential public benefits if the DCO is made. First, National Grid considers that there would be very significant public benefit arising from the grant of the DCO. That benefit can only be realised if the DCO includes the grant of powers of compulsory acquisition and temporary use. National Grid has concluded that the significant public benefits outweigh the effects of the DCO upon persons who own property in the Order limits such that there would not be a disproportionate interference with their Article 8 and Article 1, First Protocol rights. The need for the connection that will be brought about by the Authorised Development is well established and is of national importance, as detailed in the Project Need Case (Document 7.1). Second, those affected by the exercise of compulsory acquisition or temporary use powers will be entitled to compensation and National Grid has the resources to provide such compensation.

12.2.3 As for Article 6 of the Convention, third parties have been able to make representations on the application for the DCO whilst it is being prepared. In accordance with Part 5 of the Planning Act 2008, National Grid consulted persons set out in the categories contained in section 44 of the Planning Act 2008. This included the known owners and occupiers of land within the Order limits and those who might be able to make claims either under section 10 of the Compulsory Purchase Act 1965, or under Part 1 of the

Land Compensation Act 1973. This would include the beneficiaries of restrictive covenants and other rights that would be overridden by the exercise of powers in the draft DCO.

- 12.2.4 Furthermore, representations can be made by way of objections to the application in respect of any notice given under section 56 of the Planning Act 2008 ('Notifying persons of accepted application'). That Act provides for a detailed examination of any application for a DCO by an independent Examining Authority. The Examination includes careful scrutiny of any powers of compulsory acquisition or other compulsory powers, to ensure that these are justified and proportionate. Although the examination is a process mainly conducted in writing, where the Examining Authority receives one or more requests for a compulsory acquisition hearing from affected persons within the date specified, it must cause a hearing to be held. All affected persons are invited to these compulsory acquisition hearings, and have the opportunity make representations about the compulsory acquisition requests.
- 12.2.5 Should the DCO be made, a person aggrieved may seek to challenge the DCO by judicial review in the High Court. In relation to disputes about compensation, affected persons have the right to apply to the Upper Tribunal (Lands Chamber), an independent Tribunal.
- 12.2.6 For these reasons, National Grid considers that the inclusion of powers of compulsory acquisition would not breach the Convention rights of those whose land is affected and that it would be appropriate and proportionate to make the DCO, including the grant of powers of compulsory acquisition.

13 Conclusions

13.1 NEED FOR THE NORTH WALES CONNECTION PROJECT (CHAPTER 3 WITHIN THIS DOCUMENT)

13.1.1 Parts 2 and 3 of NPS EN-1 sets out that it is critical that the UK continues to have secured and reliable supplies of electricity as part of the transition to a low carbon economy.

13.2 SCOPE OF COMPULSORY ACQUISITION (CHAPTER 4 WITHIN THIS DOCUMENT)

13.2.1 The draft DCO contains powers of compulsory acquisition and other ancillary powers.

13.3 DESCRIPTION OF THE LAND SUBJECT TO COMPULSORY POWERS AND OTHER POWERS (CHAPTER 5 WITHIN THIS DOCUMENT)

13.3.1 The land to be subject to the compulsory acquisition powers covers an area of approximately 744 hectares.

13.4 PURPOSE FOR WHICH THE POWERS ARE SOUGHT (CHAPTER 6 WITHIN THIS DOCUMENT)

13.4.1 Compulsory acquisition powers are necessary to enable construction, operation and maintenance of the proposed development. This chapter sets out the purpose for acquiring each of the interests and rights in land, without which delivery of the proposed development would not be possible.

13.5 JUSTIFICATION OF THE POWER OF COMPULSORY ACQUISITION (CHAPTER 7 WITHIN THIS DOCUMENT)

13.5.1 This chapter sets out the criteria to be satisfied for the authorising of compulsory acquisition in a development consent order. The Proposed Development provides critical transmission capacity necessary for the safe and secure connection of the new Wylfa Newydd power station.

13.6 NATIONAL GRID'S APPROACH TO ACQUIRING THE REQUIRED LAND AND RIGHTS IN LAND BY AGREEMENT (CHAPTER 8 WITHIN THIS DOCUMENT)

13.6.1 This chapter outlines National Grid's approach to landowners to seek voluntary agreements where possible for all requisite land and interests in land.

13.7 RELATED APPLICATIONS, ORDERS, CONSENTS (CHAPTER 9 WITHIN THIS DOCUMENT)

13.7.1 In addition to the development to be consented by the draft DCO there are other consents required relating to matters such as Natural Resource Wales assents. It is not considered that securing these present any issues for the North Wales Connection project.

13.8 SPECIAL CATEGORY LAND (CHAPTER 10 WITHIN THIS DOCUMENT)

13.8.1 The Proposed Development will affect land categorised as special category land in the Infrastructure Planning (Applications: Prescribed Forms and Procedures) Regulations 2009.

13.9 CROWN LAND (CHAPTER 11 WITHIN THIS DOCUMENT)

13.9.1 The Proposed Development will affect Crown land as categorised in S135 of the Act

13.10 JUSTIFICATION FOR INTERFERENCE WITH HUMAN RIGHTS (CHAPTER 12 WITHIN THIS DOCUMENT)

13.10.1 The inclusion of powers of compulsory acquisition would not breach the Convention rights of those who are affected and that would be appropriate and proportionate to make the draft DCO, including powers of compulsory acquisition.

13.10.2 Whilst private interests will be affected, there is a compelling case in the public interest for the grant of the compulsory acquisition powers needed to allow the North Wales Connection project to proceed.

13.10.3 For these reasons, the inclusion of powers of compulsory acquisition within the draft DCO in respect of land and rights in land as set in the Book of Reference (**Document 3.3**) and shown on the Land Plans (**Document 4.2**) is justified, and the draft DCO should be granted containing these powers.

13.10.4 For the reasons set out in this statement, the compulsory acquisition of the land and rights, and the temporary use of land, as set out in the Book of

Reference and shown on the Land Plans is justified due to National Grid's approach summarised below;

- Careful analysis of the design to ensure that no more land than is needed is acquired or rights sought over it to be able to construct operate and maintain the Proposed Development;
- Checking of the class of interest, rights or power in relation to each plot to ensure that a superior right is not taken unnecessarily;
- Diligent enquiry to ensure negotiation with the right people;
- Engagement with all Persons with an Interest in Land (PILs) to negotiate the rights required on a voluntary basis;
- Negotiations based on National Grid's standard Lands Rights Strategy. A fair and reasonable approach, previously accepted on DCO projects;
- Continued negotiation before and throughout the examination process.

APPENDIX A – ILLUSTRATIVE TUNNEL CROSS SECTION

Page intentionally blank

Legend / Allwedd

- Indicates rough excavation profile
- Minimum required area for specific cross section
- Land interest area

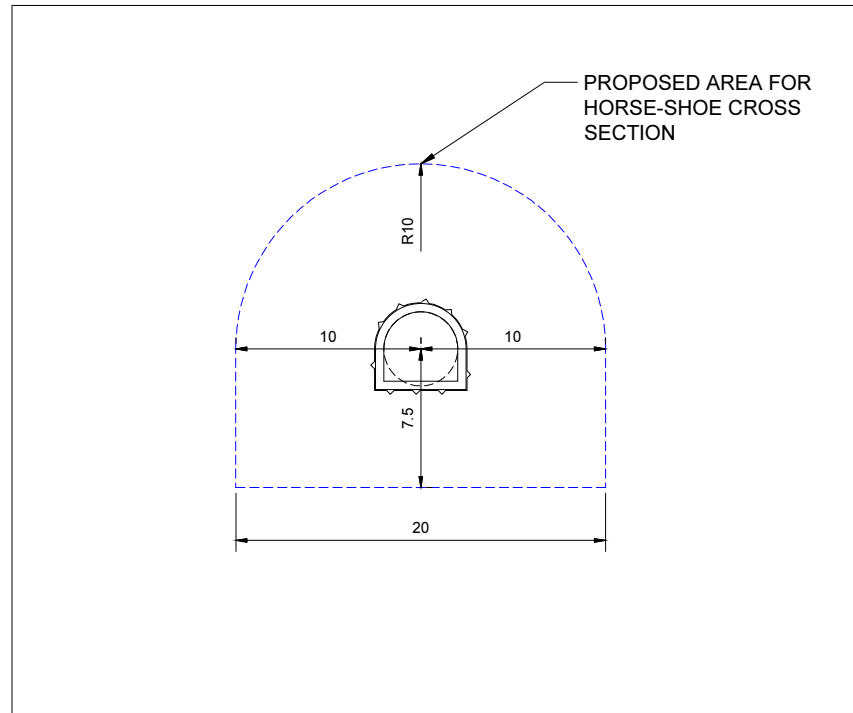

HORSE-SHOE CROSS SECTION -
 DRILL AND BLAST

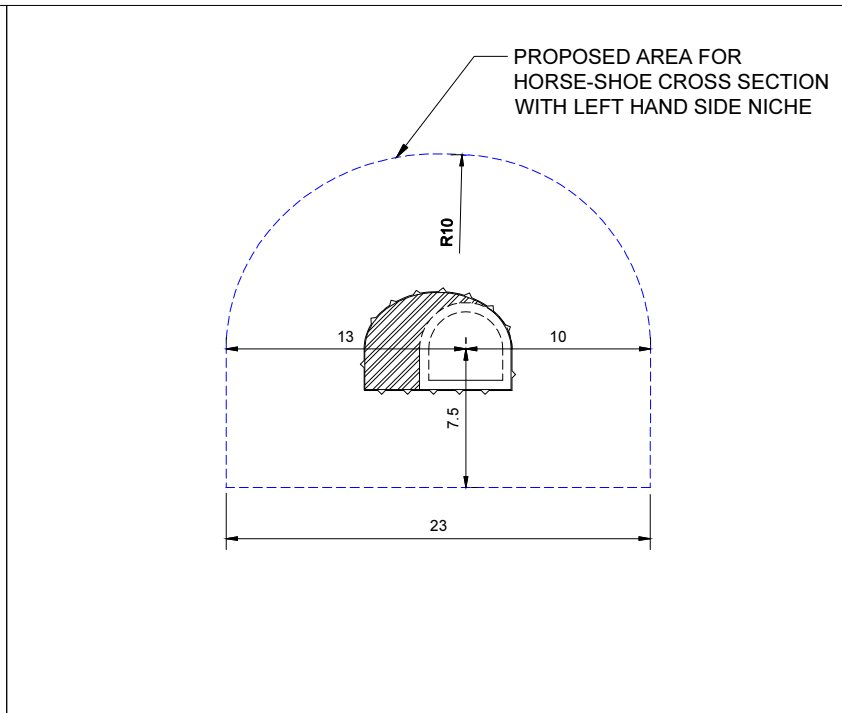

HORSE-SHOE CROSS SECTION WITH LEFT
 HAND SIDE NICHE - DRILL AND BLAST

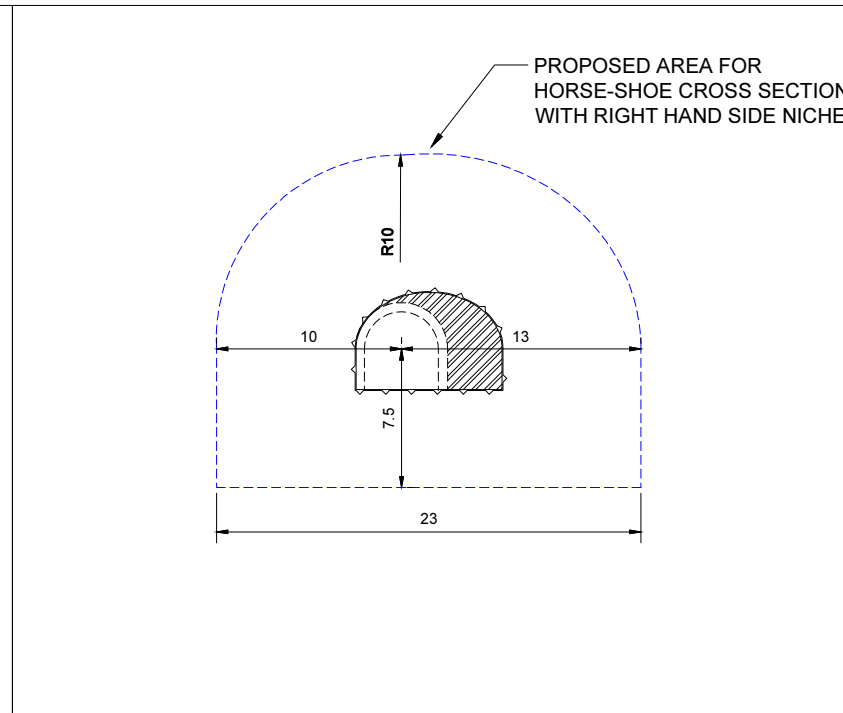

HORSE-SHOE CROSS SECTION WITH RIGHT
 HAND SIDE NICHE - DRILL AND BLAST

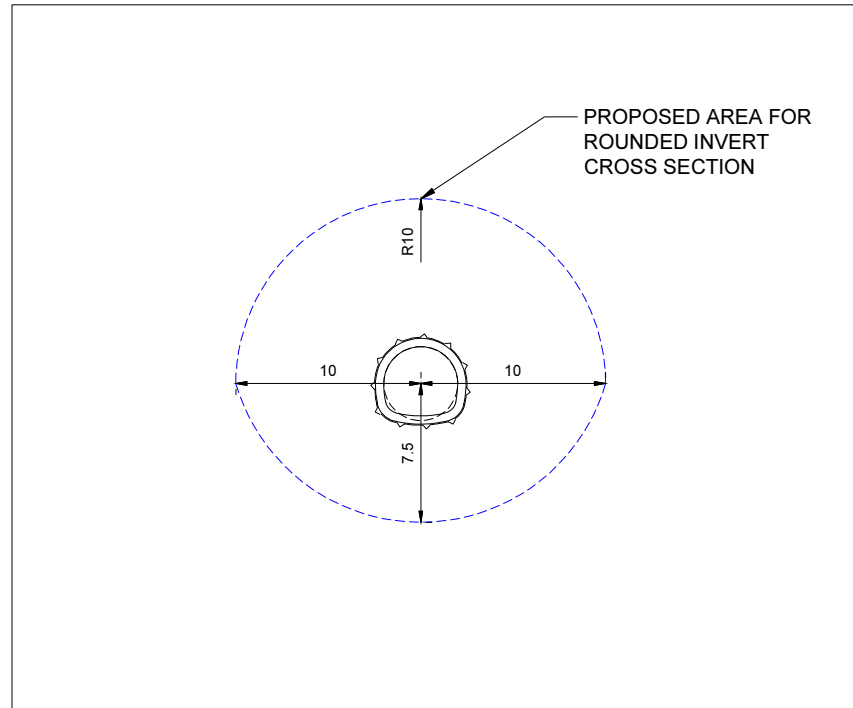

ROUNDED INVERT CROSS SECTION
 - DRILL AND BLAST

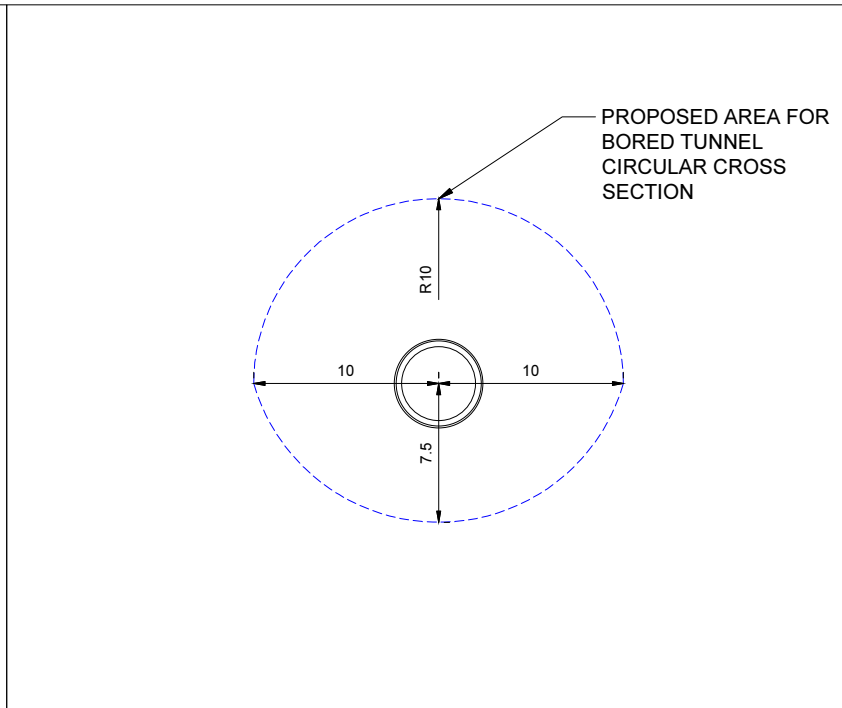

CIRCULAR CROSS
 SECTION - BORED TUNNEL

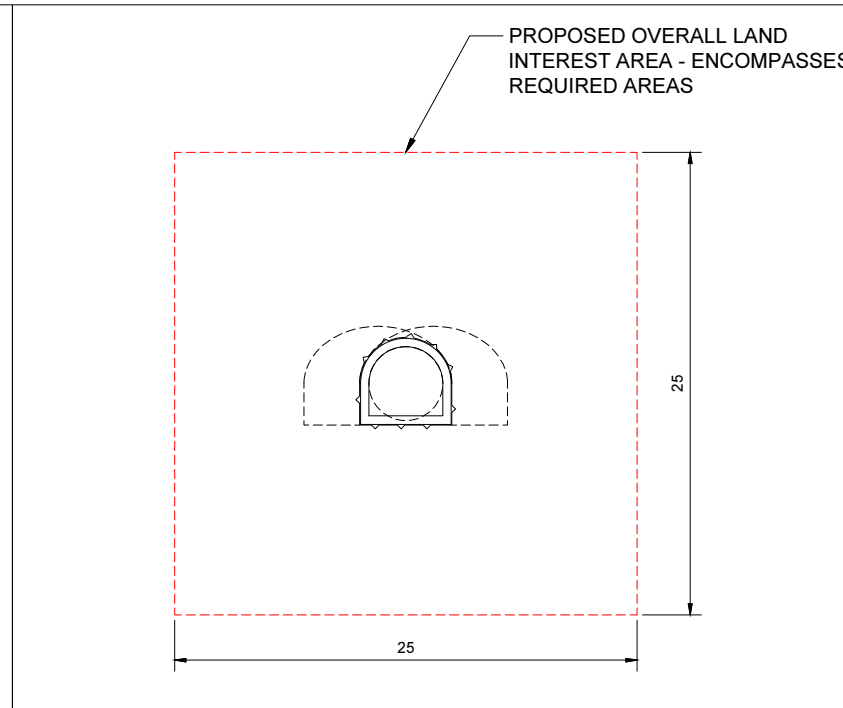

COMBINED REQUIRED AND
 OVERALL LAND INTEREST AREA

Notes / Nodiadau

1. This drawing is scaled at paper size A1, therefore any prints taken at smaller sizes will affect accuracy of the measurement units and should not be scaled against.
2. All dimensions in metres.
3. Drawing shows the indicative construction methods, cross sections and areas anticipated to be required for the construction. Actual requirements will be dependant on the ground conditions encountered and the support plus ground treatment installed during tunnelling.

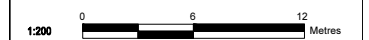

BACKGROUND MAPPING INFORMATION HAS BEEN REPRODUCED FROM THE ORDNANCE SURVEY MAP BY PERMISSION OF ORDNANCE SURVEY ON BEHALF OF THE CONTROLLER OF HER MAJESTY'S STATIONERY OFFICE. © CROWN COPYRIGHT ORDNANCE SURVEY. NATIONAL GRID ELECTRICITY - 100024241. NATIONAL GRID GAS - 100024888.

Rev / Description	Date / Day/Month	Author / Signature	Drawn / Checked	Checked / Verified	Approved / Authorised
A		FOR DCO SUBMISSION	KJ	SR	RP

Title / Teitl

THE NATIONAL GRID
 (NORTH WALES CONNECTION PROJECT) ORDER
 DESIGN PLAN: ILLUSTRATIVE TUNNEL CROSS SECTION
 REGULATION 5(2)(o)
 SHEET 3 OF 3

GORCHYMYN NATIONAL GRID
 (PROSIECT CYSYLLTIAD GOGLEDD CYMRU)
 CYNLLUN DYLUNIO: DARLUN O GROESTORIAD Y TWNEL
 RHEOLIAD 5(2)(o)
 DALEN 3 O 3



Application Number / Rhif y Cais
 EN020015

National Grid Drawing Reference / Cyfeirnod Llunaid National Grid
 DCO_DE/PS/07_03

Scale / Graddfa	Sheet Size / Safon Llywodraeth	Sheet / Dalen	Issue / Cyfnewid
1:200	A1	SHEET 3 OF 3	A

APPENDIX B – LOCATION PLAN

Page intentionally blank



THE NATIONAL GRID (NORTH WALES CONNECTION PROJECT) ORDER
LOCATION PLAN

GORCHYMYN NATIONAL GRID (PROSIECT CYSYLLTIAD GOGLEDD CYMRU)
CYNLLUN LLEOLIAD CYFFREDINOL

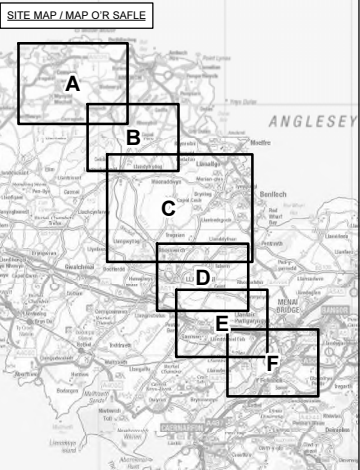
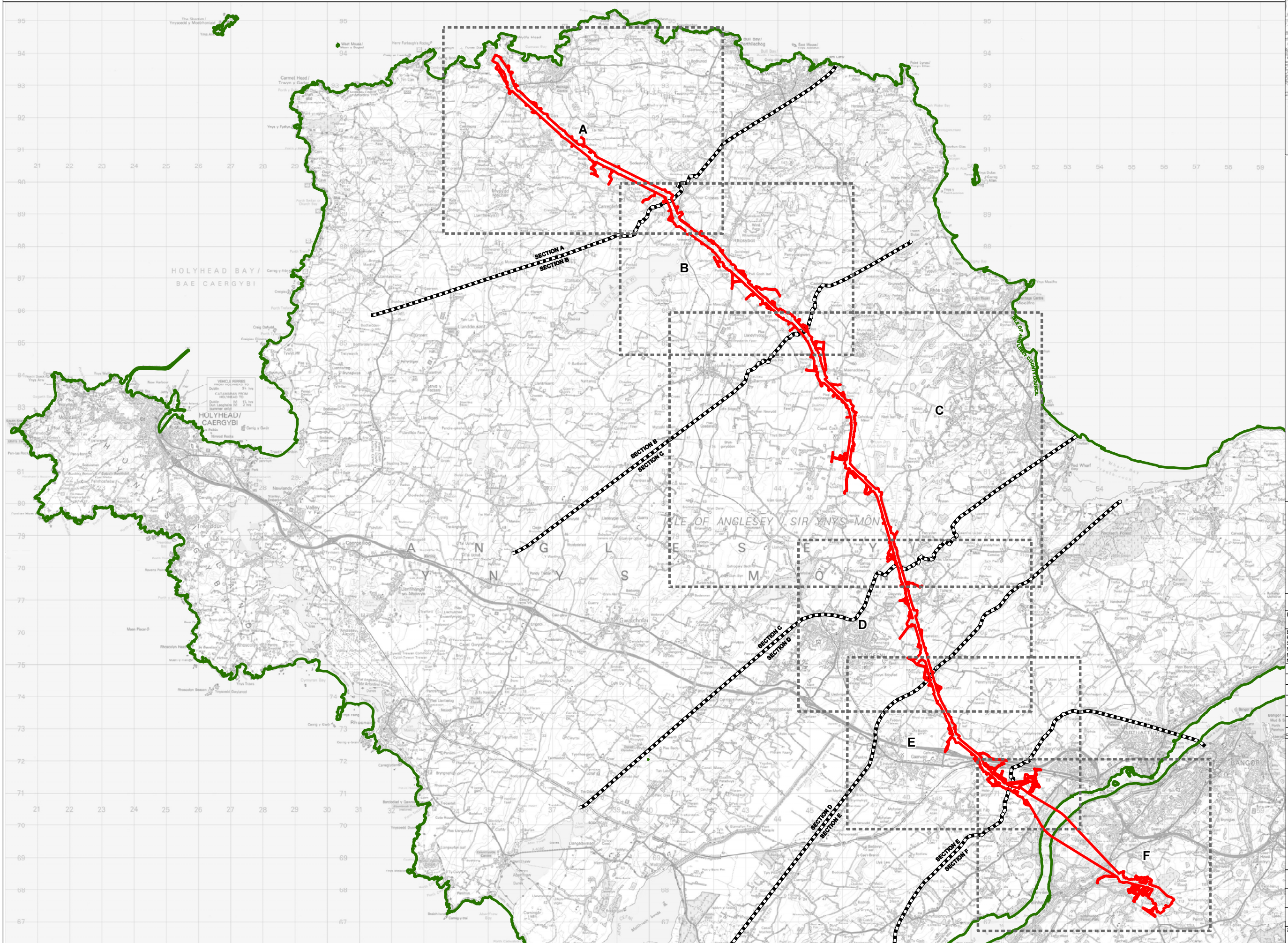

Legend / Allwedd

- LOCAL AUTHORITY BOUNDARY
- ORDER LIMITS
- SECTION BOUNDARY
- SHEET INDEX

Notes / Nodiadau

This drawing is scaled at paper size A1, therefore any prints taken at smaller sizes will affect accuracy of the measurement units and should not be scaled against.

The OS Boundary Line (Local Authority Boundary) data has been mapped against the OS 1:10,000 Scale Raster mapping and therefore will not be accurate when displayed at a different scale.

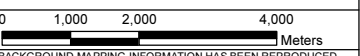

BACKGROUND MAPPING INFORMATION HAS BEEN REPRODUCED FROM THE ORDNANCE SURVEY MAP BY PERMISSION OF ORDNANCE SURVEY ON BEHALF OF THE CONTROLLER OF HER MAJESTY'S STATIONERY OFFICE. © CROWN COPYRIGHT ORDNANCE SURVEY. NATIONAL GRID ELECTRICITY - 100024241. NATIONAL GRID GAS - 100024886.

Issue / Cyhoeddiad	Date / Dyddiad	Remarks / Sylweddau	Drawn / Tynnydd	Checked / Gwirneidd	Approved / Cymharwydd

Title / Teitl

THE NATIONAL GRID
(NORTH WALES CONNECTION PROJECT) ORDER
LOCATION PLAN

GORCHYMYN NATIONAL GRID
(PROSIECT CYSYLLTIAD GOGLEDD CYMRU)
CYNLLUN LLEOLIAD CYFFREDINOL



Scale / Graddfa	Sheet Size / Mensi / Dimensi	Sheet / Ddeddf	Issue / Cyhoeddiad
1:55,000	A1	SHEET 1 OF 1	A

